

A bachelor's thesis

Berlin – Amsterdam in less than five hours –
Solutions for the acceleration of rail passenger traffic



In association with:

UNIVERSITY OF TWENTE.

Technische Universität Berlin



Joran M. Sanders

University of Twente

January 4, 2011

Preface

When I came to Berlin on a holiday two years ago I immediately fell in love with the city and right then and there I decided that I wanted to live in Berlin for a while. The perfect opportunity presented itself when it was time to complete my bachelor with the bachelor's assignment. After some trial and error e-mail sending I came into contact with Christian Blome from the department of "Schienenfahrwegen und Bahnbetrieb" at the Berlin University of Technology. He was willing to devise an assignment for me and tutor me along the way, so I could accomplish my Berlin experience.

To make the theme international and relevant issue for me I got to investigate the railway corridor that I now use so often to go to and from Berlin. Though I study Civil Engineering this theme was completely new and at the start I had absolutely no knowledge in the field of railway carried passenger transport. Next to the language differences this was one of the greatest challenges I had to overcome.

Luckily I received plenty of support from both my supervisors and all the people at the department. I was allowed to occupy one of the office desks in the doctorates office through which I felt quite honoured to work in a room with so many intelligent people. I would like to start to thank them because they made my days fun and the many lunches we enjoyed together a lot more interesting. I'd like to thank Christian Weise who always kept his door open so I could walk in and ask my questions; yes, comically all the department's employees are named Christian. Thanks to Christian Blome for giving me such a wonderful opportunity and believing that I could pull off everything I had planned to achieve, though it proved to be a little too much.

Auf jeden fall hat es mir unglaublich viel spaß gemacht, und ich komme ja sicher nochmals wieder nach Berlin. Hoffentlich um an ein Paar Masterkursen teil zu nehmen beim Fachgruppe. Ich danke euch allen und sage nur bis zum nächsten Jahr!

Summary

Since the 1970s and 1980 essential links in the European rail network have gradually been upgraded or made suitable for high speed trains. The reasons why these links were improved are to increase the link capacity, to increase speed in slow sections and to improve long distance accessibility. Some 40 years later the European rail network provides fast medium distance passenger transport within separate nations, but also on international links.

One of these international links is the Amsterdam – Berlin railway corridor which connects these two major European conglomerate areas. Other transport modes such as car and air traffic are also available on this corridor. Travel times of these three transport modes vary from 255 minutes for air traffic to 420 minutes for both car and train. Air traffic possesses the majority of passengers that use this corridor, because travel time plays a major role in mode choice. To make the railway corridor more competitive with other transport modes travel time needs to be reduced to approximately 300 minutes.

This research focuses on the questions of what causes the high travel time for railway traffic and which solutions are available to reduce the travel time and make the railway corridor more competitive. To answer these questions key concepts in international railway traffic are explained, the current situation is analyzed and the problems that induce a loss of travel time identified. For each of these problems solutions are then generated and advantages and disadvantages described. Finally solutions are compiled into three variants, low, intermediate and high-end, to achieve the wanted outcome and a preferable solution is chosen.

Currently the Amsterdam – Berlin corridor is operated in a two hour tact, and in both Germany and the Netherlands it follows a national IC schedule. The German corridor section uses 15 kV 16,7 Hz AC power supply and both PZB and LZB train control systems. The Dutch section uses 1500 V DC power supply and the ATB. Therefore the locomotive is changed at the border station of Bad Bentheim together with the train staff. The staff needs to possess the national language and the operator needs to have knowledge of both national rules and regulations and of the corridor. Allowed speeds in Germany vary from 250 km/h on the Hannover – Berlin section to 200 km/h and 160 km/h between Hannover and the Dutch border. In the Netherlands speeds is limited to 130 km/h on the entire section. Because the trains that operate the Amsterdam – Berlin corridor consist of pulled carriages the maximum speed for the train is limited to 200 km/h.

One of the key concepts in international railway traffic is interoperability; interoperability means the ability of the trans-European rail system to allow the safe and uninterrupted movement of high-speed trains which accomplish the specified levels of performance. This ability rests on all the regulatory, technical and operational conditions which must be met in order to satisfy essential requirements. This is stated in several European regulations such as the EC guideline 96/48/EC of July 23 1996 and more specific in the TSI. Which corridors belong to the European railway network is stated in TEN, these corridors are divided in conventional and HSR. Following the goal of an interoperable European railway system the EU has developed and is still developing the unification of all European guidance- and safety systems under the name ERTMS. ERTMS exists of four components; the first is an international railway management system, the second the unification of all European signalling systems and regulations, the third a single European train control system named ECTS and the fourth a single voice and data communication system, GSM-R.

The problems that induce a loss of travel time on the Amsterdam – Berlin railway corridor can be divided into technical and operational problems.

The technical problems are:

1. The difference in power supply
2. Different guidance- and safety systems
3. Track speed limit
4. Allowed train speed limit

Operational problems consist of:

1. Available concession space on the corridor
2. Language and knowledge of the train staff
3. Amount of integrated stops

Power supply, guidance- and safety systems and staff training cause problems with the interoperability. These problems induce a loss of time at the border crossing where locomotive and staff have to be changed. On the entire corridor speed for both track and train is limited, and every time the train halts time is lost. Each of these problems can be overcome in itself due to several measures, but solving just a single problem of interoperability does not reduce any travel time. To reduce the travel time the entire problem of interoperability needs to be overcome at once. Therefore several scenarios of solutions have been made, at one end low cost, low effectiveness measures and at the other high cost, high effectiveness. For each of these scenarios the expected total travel time, the reduction of travel time, passenger growth, investment costs and cost growth ratio are calculated (Table 1).

Table 1: Summary of thesis results

Scenario	Total travel time	Traveltime reduction (min)	Estimated passenger growth	Cost (million euro)	Cost/ Growth ratio
Current	6h 53m (413 min)	-	-	-	-
Low-end	6h 07m (367 min)	46	1.69%	69.3	4242
Intermediate	5h 56m (356 min)	57	2.09%	74.2	4524
High-end	5h 32m (332 min)	81	2.97%	184.2	11136

From the results of the calculations can be concluded that a reduction of total travel time to less than 5 hours is not realistic, though with even more alterations possible. Because the Amsterdam – Berlin corridor has a relatively low demand the most preferable variant would be the most cost effective. This would be a solution which requires no extreme investments and interventions on the corridor. This would be both the low-end and the intermediate scenario depending on the goals of the train operating companies.

Table of contents

Preface.....	I
Summary	II
Table of contents.....	IV
1. Introduction.....	1
1.1 Theme introduction.....	1
1.2 Scope	3
1.3 Objective.....	4
1.4 Research questions.....	5
1.5 Research approach.....	5
2. Theoretical framework.....	7
2.1 Current situation	7
2.2 Introduction to interoperability	10
3. Analysis current issues	14
3.1 Introduction.....	14
3.2 Power supply	14
3.3 Railway guidance- and safety system.....	18
3.4 Speed limits	21
3.5 Operational constraints.....	23
4. Generating solution variants	25
4.1 Introduction.....	25
4.2 Track based technical solution variants	25
4.3 Train based technical solution variants.....	27
4.4 Operational solution variants.....	28
4.5 Solution scenarios	29
4.6 Effects.....	30
5. Conclusions and recommendations	35
5.1 Conclusions.....	35
5.2 Recommendations.....	36
Literature index	37
Appendix.....	38
Appendix A: Timetable IC Berlin Schiphol	38
Appendix B: Elaboration on train control systems.....	39

1. Introduction

1.1 Theme introduction

Since the 1970's and 1980's essential links in the European rail network have gradually been upgraded or made suitable for high speed trains. The reasons why these links were improved are to increase the link capacity, to increase speed in slow sections and to improve long distance accessibility. Some 40 years later the European rail network provides fast medium distance passenger transport within separate nations, but also on international links (Vickerman, 1997).

A perfect example of the developments high-speed rail network that provides medium distance passenger transport is Germany. In Figure 1 a map is shown of all the railway corridors that have either been upgraded or made suitable for high-speed rail. As shown, not only does the high-speed rail network provide national, but also several international links. International links have been established with Denmark, Austria, Switzerland, France, Belgium and the Netherlands and provide medium distance passenger transport corridors between major conglomerate areas.



Figure 1: German high speed rail network (Source: DB Netz AG, 2009)

Simultaneously the highway network has been improved and its capacity has been expanded drastically. Also air transport has evolved from mainly luxury and business long distance flights to functional and affordable passenger transport for medium distance flights. As a result highway and air transport provides excellent substitutes for medium distance passenger transport by train and throughout the years have always dominated the medium distance passenger transport market.

This domination of highway and air transport also applies to the major East-West corridor from Amsterdam, the Netherlands, to Berlin, Germany. A direct highway (Highway number E30, see also Figure 2) forms a perfect link between these conglomerate areas. Airports are available near Amsterdam (Schiphol airport) and in Berlin (Berlin Schönefeld and Berlin Tegel airport) which provides a suitable link for air passenger transport.

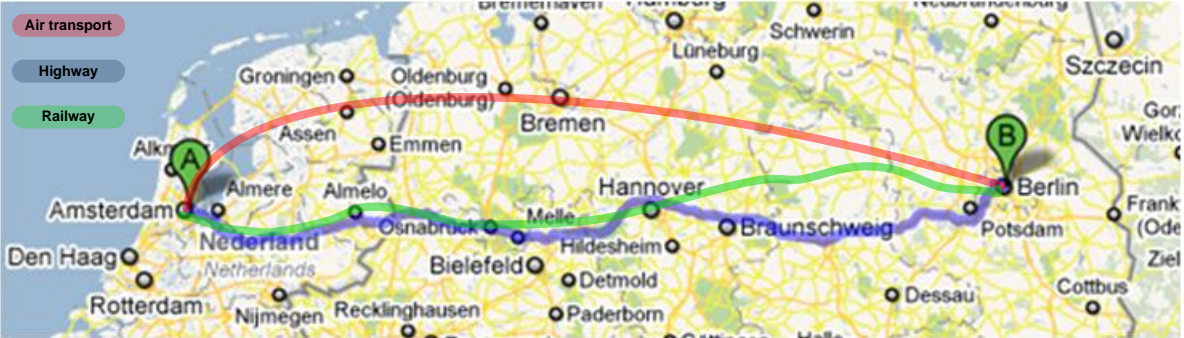

Figure 2: Amsterdam - Berlin corridor (Source: Google Maps, 2010)

Between the three available modes of passenger transport available on the Amsterdam – Berlin corridor travel time shows some variation. Travel time for a car consists of in vehicle travel time and additional stopping time for pausing and refuelling. Travel time for air passenger travel consists of in vehicle travel time, but also additional boarding time and travel time from and to the airport. Though the train on this corridor does not go to Amsterdam central station but to the airport Amsterdam Schiphol, it is possible to change trains without too much loss of travel time. In Berlin this is the same, with a change of trains, it is possible to get nearly anywhere in the city centre without a great loss of travel time while when coming from Tegel or Schönefeld airport it takes a much greater amount of travel time. Table 2 shows the different transport modes available on the Amsterdam – Berlin corridor and the needed time for each of its attributes. In the last column the total travel time for each mode is summarized.

Table 2: Mode travel time

	In vehicle travel time (min)	Additional boarding time (min)	Additional travel time (min)	Additional stopping time (min)	Total travel time (min)
Car ¹	390	None	None	30	420
Train ²	390	None	30	None	420
Airplane ³	75	90	120	None	255

¹ Source: maps.google.com
² Source: www.ns-hispeed.nl
³ Source: www.klm.com

Li and Wachs (2000) state that the most important incentive for mode choice is travel time and also influential is trip cost. It is obvious that of the three available modes air transport is preferred while it has by far the shortest travel time and therefore delivers the highest level of service to its passengers. Due to the introduction of low cost airlines prices of air transport have dropped which increased the preference for air travel even more. Though car and rail transport have the same travel time, car transport provides a higher level of service. This is mainly caused by two factors, first a car has the advantage that you can take it at any given moment and go to any given place, therefore offers a great deal of freedom of transportation. Second the out of pocket cost are low compared to rail transport, while sunk cost are not taken into account by your average car driver. A car driver already made the expenses for the purchase, payment of taxes and insurance have already been made, which he will not calculate into the actual trip costs. When buying a train ticket all of these sunk costs are directly priced into the cost of the ticket and therefore it seems much more expensive to a traveller (Campos, Rus & Barron, 2006). Both rail- and air transport have an additional travel time to and from the railway station or airport to the final destination. Because of these disadvantages rail passenger transport can hardly compete with the other available modes and it is used far less.

1.2 Scope

The west-east railway corridor Amsterdam – Berlin provides a direct link for medium distance passenger transport between these two major conglomerate areas. In Figure 3 the Amsterdam – Berlin corridor is shown and its most important links to other parts of the railway network. As shown in Figure 3 there are more routes available to travel from Amsterdam to Berlin. The current route from Schiphol via Amersfoort, Hengelo, Osnabrück, Hannover and Stendal to Berlin Hauptbahnhof and Ostbahnhof is the most direct route. Although there are alternative routes available, these possibilities will not be explored in this research, only the solutions that relate to this route.



Figure 3: Amsterdam - Berlin railway corridor

The German rail network is property of Deutsche Bahn Netz (DB Netz), they grant permissions to use the track and rent it to every operator that wants to use the rail network. In the Netherlands the railway network is managed by ProRail, which has the same functions for the Dutch rail network as DB Netz has in Germany. These networks are used by a number of rail passenger transport and rail cargo firms that each want to use the available slots on the rail network. The international train Amsterdam – Berlin is exploited by Deutsche Bahn Fernverkehr, one of Germany's major rail operators. In the Netherlands the international train uses a time slot from a regular Inter City (IC) train that is owned by the Nederlandse Spoorwegen (NS), and therefore has to make the same stops as the regular IC train. These four firms play the major roles on this corridor but are not important to the outcome of this research. With this research, possible solutions are formulated and recommendations are given.

In the current situation few passengers use the international railway corridor between Amsterdam and Berlin. This can be explained by the fact that other transport modes are available on the corridor. The other available transport modes are car and airplane. These modes can provide passengers with a higher level of service and are therefore used more. To be able to compete, the rail corridor needs to achieve a higher level of service, which can be achieved with several measures. Travel time is one of the most important incentives (Li & Wachs, 2000) therefore this study will aim at a reduction of the travel time. To achieve the wanted level of service it is estimated that a reduction in travel time from 6.5 hours to only 5 hours is needed to make the railway corridor competitive with other transport modes.

Solutions to reduce travel time can be found in different areas, such as technical, operational, economical and legal. Technical solutions can consist of different use of trains, adaptation of the existing railway track or constructing an entirely new track. Operational solutions are those regarding the adjustment of the current rail service, such as the timetable, number of stops and returning time. Economical or legal solutions are possible for example by changing tax rates, that is, increasing kerosene fuel taxes or charging every transport mode with an environmental tax stipulated by the amount of pollution. This way mode choice will be affected (Vestner, 2004). Because economical and legal solutions affect mode choice but have no effect on the reduction of travel time they are disregarded in the scope of this research. Therefore solutions for the acceleration of rail passenger traffic on the Amsterdam – Berlin corridor that will be researched are either technical or operational solutions.

In conclusion, today's market for passenger transport on the Amsterdam – Berlin corridor is dominated by car and airplane. Rail passenger transport provides a lower level of service and therefore cannot compete. To be able to compete with other transport modes travel time for rail passenger transport needs to be reduced from more than 6.5 to maximally 5 hours.

1.3 Objective

This research will give an insight in the possible solutions to accelerate rail passenger traffic on the Amsterdam – Berlin corridor. This new gained insight will provide a solid base for future designs and is gained by studying the context and origin of problems that are encountered on the corridor. These will give directions in which solutions can be found. Therefore the main objective of this research can be formulated as follows:

The main objective of this research is to explore the possible solutions and provide recommendations for the reduction of travel time for rail passenger transport on the Amsterdam – Berlin corridor. Travel time needs to be reduced to less than five hours to be able to compete with other transport modes. This is achieved by analyzing the context and current problems, generate possible solutions from this analysis, determine their effects on travel time and compare each of these variants based on a set of indicators.

1.4 Research questions

The main objective can be subdivided into several research questions that need to be answered to come to a satisfying conclusion. The research questions to achieve the main objective of this research are:

1. What are the operational and technical constraints that induce a loss of travel time on the railway corridor Amsterdam – Berlin?
2. What solution variants are there to reduce travel time on the Amsterdam – Berlin?
3. What are the effects on travel time for the generated solutions?
4. What is the preferable solution to reduce travel time on the Amsterdam – Berlin corridor?

1.5 Research approach

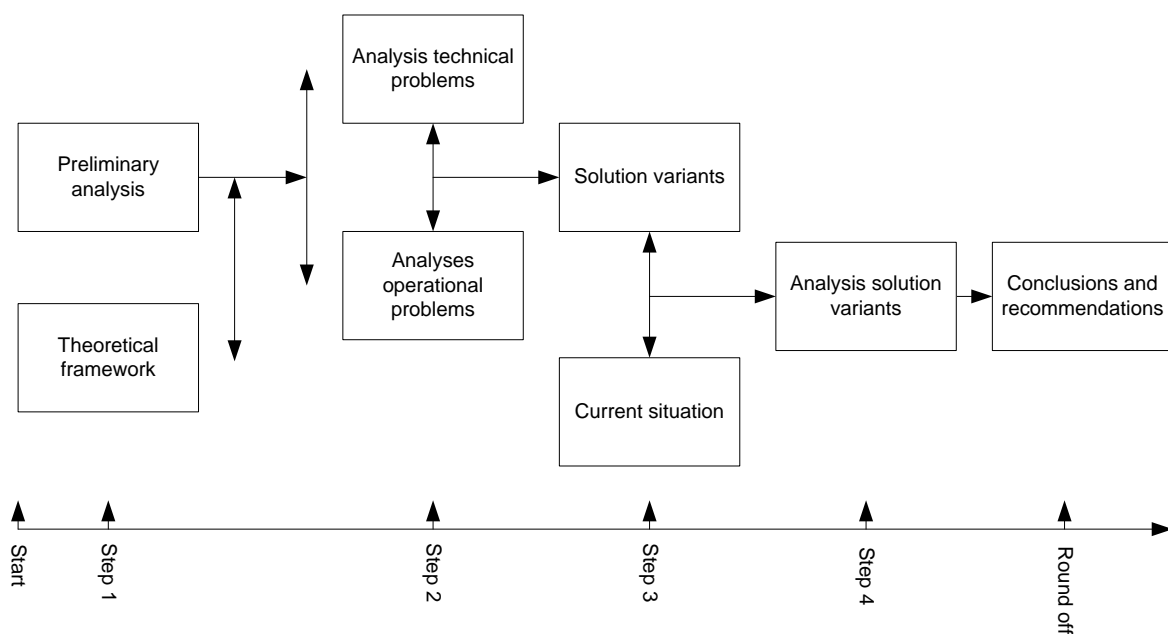

Figure 4: Research model

As is visually displayed in Figure 4, the research questions will be answered throughout the chapters of this report and finally lead to the conclusions and recommendations. In the second chapter of this report first the current situation on the Amsterdam – Berlin corridor will be outlined. Because the Amsterdam – Berlin corridor is not regarded as very important at this moment, no prior research has been done and very little information is available. In my knowledge this is the first research that explores the possibilities that this corridor can offer. The current situation will be used first and foremost to define the problems that induce a loss of travel time and furthermore as a reference for the comparison to determine the effectiveness of the generated solutions. Also introduction will be given into the key concept of interoperability. Interoperability forms the basis for international railway traffic and it is in this concept where the problems and answers can be found.

Now possessing the most basic knowledge of interoperability in international railway traffic chapter three is completely dedicated to analyze the problems (or lack of interoperability) on the Amsterdam – Berlin corridor that induce a loss of travel time. The problems are divided into two types; technical and operational problems. Both the technical and operational aspects are put into the literary context with explanations of origins and functions of several technical systems or regulations and customs of operations. With a solid background of what problems are present and from where they originate, solutions can be generated.

The solutions that are generated from the observed problems are illustrated in the fourth chapter. Each of the observed problems is elaborated with literature and the Amsterdam – Berlin corridor compared to similar situations on other tracks. From there solutions that could possibly tackle the problems that arise on the Amsterdam – Berlin corridor are selected and explained based on the prior gained knowledge of the technical and operational aspects. Positive and negative properties of each solution variant are determined so that they can be weighed to determine their effectiveness.

Because no single solutions can solely reduce the travel time to the desired level, they need to be combined into solution packages. Three solution packages will be presented with different ranges of effectiveness and costs and a preference is given based on the efficiency of the solution packages. The report is then wrapped up with the conclusions and recommendations for further research that is necessary to determine if investments in the Amsterdam – Berlin corridor are profitable and the objectives set achievable.

1.5.1 Reading instructions

If you are unfamiliar with any of the aspects of international railway traffic or railway traffic in general it is advised to read the entire thesis. The basics of railway traffic are extensively explained in chapter 3, so if you are already familiar with these subjects this chapter can be left out. For information about the Amsterdam – Berlin corridor itself chapter 2 provides the most insights and is important for the understanding of the generated and applied solutions. Chapter 4 is for the deeper insights into the possible solutions and the choices that are made to come to the solution scenarios. These results are also quickly discussed in the conclusion when deeper insights are not required.

2. Theoretical framework

In the theoretical framework a picture is drawn of the current situation on the Amsterdam – Berlin corridor. The most important elements of the corridor are featured beginning with the history of the corridor. Furthermore the operational affairs, track- and train properties are illustrated. Furthermore an introduction in the key concept of interoperability is given. Interoperability is highly important when it comes to international railway traffic, as to why and what is the current condition of interoperability will be explained later on.

2.1 Current situation

2.1.1 History and development of the Amsterdam – Berlin corridor

In cold war Europe Berlin was cut off from west-Europe until the fall of the Berlin wall in 1989. Trans European trains therefore never reached Berlin only after the fall. In 1991 the German railway network was merged once again and railway traffic from and to Berlin was once more possible. During its time of operation the line has faced a lot of changes.

The railway connection between Amsterdam and Berlin has existed since 1994 as Inter Regio (IR) line and became an Inter City (IC) in 2002. The IC Amsterdam – Berlin has operated as an independent international railway link in the Netherlands two times a day until 2005. Because of low occupancy the train was not profitable and was therefore included in the Dutch national IC network. This meant that the international train would follow the same time pattern as the regular IC trains between Hengelo and Schiphol. In Germany it has been deployed as IC from the beginning.

In the past the IC Amsterdam – Berlin has had different terminuses. At the Dutch side the train has ended at Amsterdam Central Station, until the line was altered in 2009 to end at Schiphol for several operational reasons. At the German side Berlin Hauptbahnhof has a limited capacity and no opportunity to turn, therefore the IC rides through to Berlin Ostbahnhof and once a day from- and to the destination of Szczecin, Poland.

2.1.2 Line properties

The IC Amsterdam – Berlin is operated in a two hour tact. A detailed timetable for the Amsterdam – Berlin corridor can be found in Appendix A: Timetable IC Berlin Schiphol. As an example the current route of IC 140, its stations with corresponding distances, travel time and stopping time are clearly displayed in two figures on the next page. **Error! Reference source not found.** shows the IC 140 etween Berlin Ostbahnhof and the German border station of Bad Bentheim and the section between Bad Bentheim and Schiphol.

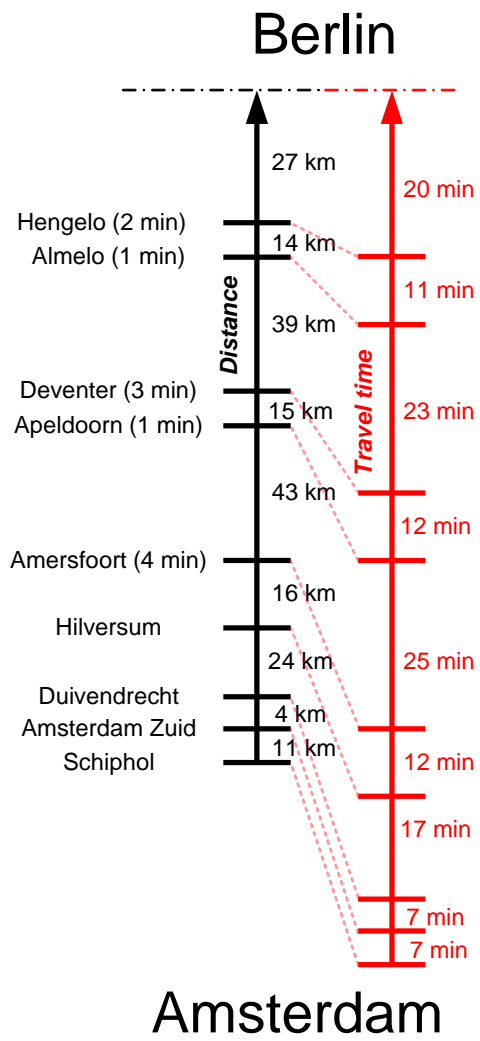
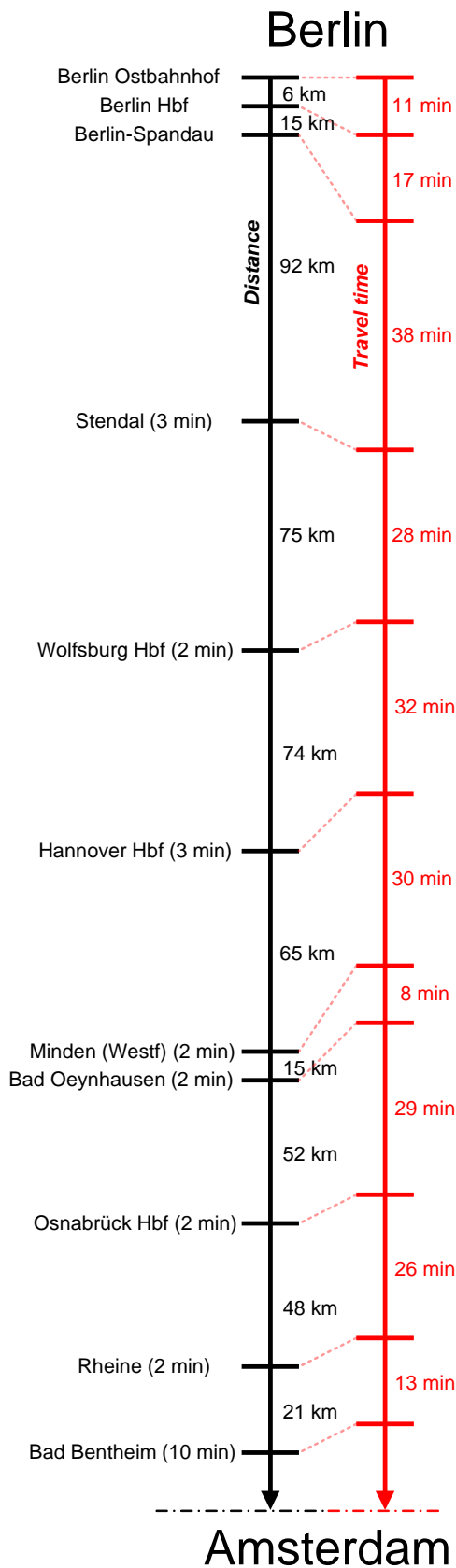

Figure 5: Comparison of distance and travel time on the Amsterdam - Berlin corridor (DB Bahn)

The line is operated with 8 carriage formations consisting of former DB Inter Regio carriages. In Germany the carriages are pulled by an electric locomotive for 15kV 16,7 Hz AC with an allowed maximum speed of 200 km/h and in the Netherlands by a 1500 V DC locomotive with an allowed maximum speed of 140 km/h. The allowed maximum speeds on each section are displayed in the first column of Table 3.

Because both locomotives are incompatible with other railway networks than the ones on which they operate they have to be exchanged at the border crossing. In the German border station of Bad Bentheim there is a railway section on which power supply can be switched between the German and the Dutch supply system. This costs approximately 10 minutes, therefore the long stopping period at this station (Figure 5).

This time is also used to switch the train operator and staff from German to Dutch and vice versa. This is because the train operator needs to be trained in the applied signalling systems in a country and have the appropriate route knowledge. Also the train staff needs to have appropriate route knowledge and most important need to be in command of the language.

Table 3: Overview section properties (source: DB Netz AG, ProRail)

Section	Maximum speed (km/h)	TEN category	Safety system	Power supply
Berlin Ostbahnhof – Berlin Hauptbahnhof	100	High speed rail (HSR)	PZB ⁴ /LZB ⁵	15kV AC (16,7 Hz)
Berlin Hauptbahnhof – Berlin Spandau	160	HSR	PZB/LZB	15kV AC
Berlin Spandau – Stendal	200/250	HSR	PZB/LZB	15kV AC
Stendal – Wolfsburg	250	HSR	PZB/LZB	15kV AC
Wolfsburg – Hannover	200	HSR	PZB/LZB	15kV AC
Hannover – Minden	160/200	HSR	PZB/LZB	15kV AC
Minden – Bad Oeynhausen	160	Conventional	PZB	15kV AC
Bad Oeynhausen – Bunde	160	Conventional	PZB	15kV AC
Bunde – Osnabrück	160	Conventional	PZB	15kV AC
Osnabrück – Rheine	160	Conventional	PZB	15kV AC
Rheine – Bad Bentheim	160	Conventional	PZB	15kV AC
Bad Bentheim - Border	130	Conventional	ATB	1500V DC
Border – Schiphol	130	Conventional	ATB	1500V DC

⁴ Punt Zug Beeinflussung or PZB will be explained in chapter 3.3.3

⁵ Linien Zug Beeinflussung or LZB will be explained in chapter 3.3.3

2.1.3 Passenger numbers

Passenger numbers specifically for the Amsterdam – Berlin corridor are not publically available. The DB also does not release passenger data to third parties or for research purposes for that matter. This is to protect company secrets and evade possible competition. To get an impression passenger data was collected during personal trips that were made on the Amsterdam – Berlin Corridor. On each of these personal trips passenger numbers on board were counted. Because the line is part of the intercity network in both the Netherlands and Germany the relevant passenger number is that when crossing the border. Estimates based on the counting are displayed in Table 4. These are average daily numbers, estimated with data collected on five return trips. Because this data is very scarce corrections for time of day measured have been applied. Also the assumption is made that Mondays to Tuesdays and Saturdays are equal and both Friday and Sunday deviate. The main reason for this increase in passenger numbers is weekend travellers that normally go on Friday and return on Sunday, which leaves Saturday as a less popular day and therefore equal to other weekdays.

Table 4: Estimated passenger numbers

	Monday – Tuesday & Saturday	Friday	Sunday
Amsterdam – Berlin	1408	3776	2688
Berlin – Amsterdam	1472	3008	3712

2.2 Introduction to interoperability

2.2.1 Definition

Today interoperability is one of the key concepts for international railway transport in Europe. It is a concept that shall reoccur often in this thesis. Therefore a short explanation is preferred of what this concept beholds, its history and its application in today's European railway network.

As stated in the European Commission (EC) guideline 96/48/EC of July 23 1996, the definition of interoperability for European high-speed rail systems is as follows: Interoperability means the ability of the trans-European high-speed rail system to allow the safe and uninterrupted movement of high-speed trains which accomplish the specified levels of performance. This ability rests on all the regulatory, technical and operational conditions which must be met in order to satisfy essential requirements.

2.2.2 History of interoperability in Europe

In 1866 the foundations for an interoperable European railway network were established in a set of regulations for example about the maximum width of trains. The first multinational European railway project was realized in 1882 with finishing the Gotthardtunnel between Germany, Switzerland and Italy. In most of the European countries "standard gauge" rail track width was set to 1435 mm in the same year. Countries that until today use a different track width are Spain, Portugal, Ireland, Finland and Russia.

Crossing borders by train is made possible since 1922 by the "Union internationales des Chemins de fer codex" (UIC) in which arrangements for technical, operational and even organizational requirements are set. In case of international railway traffic it is usual that locomotives are changed at the border crossing. This proposes a serious problem when considering international high-speed rail traffic due to long waiting periods. This is even more difficult when dealing with indivisible train

compositions, this problem used to be solved by using diesel trains that therefore did not need to be changed at the border (Dietmar & Hecht, 2008).

2.2.3 Limitations of interoperability

From the mid sixties European railway operators raised the speed of railway traffic as an answer to the growing competition of car- and air traffic. Due to a longer braking distance for high-speed railway traffic, the current signalling systems became insufficient. The French authorities solved this by increasing the signalling length over two normally used signalling blocks. The German authorities took another route and used an electrical signalling system inside the trains to “increase the signalling sight”. Another development was that new electrical motors that use different voltages than offered, and therefore the voltage is switched on the train itself. This made it possible for the locomotives to use a wide variety of electrical systems with different voltages.

In 1981 the first high- speed rail track was opened between Paris and Lyon, on which the TGV operates. Here a completely different voltage was used than the rest of the French railway network and therefore creating the first not-interoperable railway line. In Germany the new railway lines are equipped for high- speed rail as well as normal railway traffic and even freight trains, and therefore the normal voltage is also maintained on these lines. But also the new German railway lines were not completely interoperable while every train that was allowed on this tract needed to suffice certain requirements. With the new ICE trains that provided high- speed rail traffic in Germany also neighbouring railway systems were linked, and cities such as Vienna, Brussels, Amsterdam, Zurich, Bern and Geneva.

The first genuine attempts to create an international interoperable high- speed railway system were the building of the Channel- tunnel with Eurostar connection between London and Paris and the PBKA (Paris, Brussels, Köln (Cologne), Amsterdam) project with its Thalys trains. The opening of the high-speed railway link between London, Paris and Brussels in 1994 was the first challenge of the development of interoperable trains. The PBKAL/F project had to deal with four different power and signalling systems within the project area. Therefore the Thalys was developed based on the French TGV that would operate on the links between Paris, Brussels, Amsterdam and Brussels- Köln. The links Brussels-Köln-Frankfurt and Amsterdam-Köln are operated by an ICE3-M type train based on the German ICE and the links Paris-Lille-London and Brussels-Lille-London are operated by Eurostar trains. With these trains a properly functioning international railway network was created (Dietmar & Hecht, 2008).

2.2.4 European railway network

Already in 1973 the UIC proposed a European infrastructure policy that defined the major corridors for European railway traffic consisting of existing tracks, expansion tracks and newly build tracks. Unfortunately these plans were never elaborated, and only in 2004 the UIC came with a new plan. The new title was European Infrastructure Masterplan (ERIM), in which also was set that these railway corridors needed to be equipped with European Train Control System (ETCS) to improve the interoperability.

For a European high- speed railway network the UIC presented it first plans in 1990. The only solution to the differences in electrification and security systems between the European countries that qualified was to equip each train with several operational systems. The development of a united

European guidance- and safety system would take another 15 years and came in the form of European Railway Traffic Management System (ERTMS).

ERTMS was originally developed to supplement ETCS in the unification of European guidance- and safety systems. It consists of four parts:

- Europirails; Railway traffic management system
- INESS; INtegrated European Signalling System
- ETCS; European Train Control System
- GSM-R; Voice and data communication

From these four systems Europtirails is already used to exchange information about international trains, but not to manage the railway traffic. INESS has just begun as a research project and still has a long way to go. ETCS is now being applied on the first European tracks and GSM-R is applied widely while it is being equipped into other train control systems. This means that there still a lot has got to happen before Europe has a proper interoperable railway network (Dietmar & Hecht, 2008).

2.2.5 Establishing an interoperable railway system

The treaty establishing the European Economic Community (EEC) proposed numerous progressive ideas among which a Trans European Network (TEN) that was elaborated in the treaty of Maastricht. The TEN-network is shown in Figure 6. Based on these treaties a number of guidelines were drawn up and not before long the Technical Specifications Interoperability (TSI) and the European Standard (ES) followed. With that the high-speed railway network took up the role of pioneer for a united Europe.

For the realization of the TEN-network the EU determined where the European railway network should be expanded with newly build routes, upgraded routes and the remaining TEN routes. The building costs of these projects cannot be expected to completely be financed by the countries themselves and are therefore partially financed by the EU.

The subdivision of the ECC for “Technical harmonization” worked on a policy towards legal and technical regulations for the European railway system. They set aside the concept of compatibility for the newly found concept of interoperability and this way the Technical Specifications for the Interoperability (TSI) originated (Dietmar & Hecht, 2008).

2.2.6 Interoperability on the Amsterdam – Berlin corridor

As depicted in Figure 6 the corridor Amsterdam – Berlin is part of the TEN-network. It consists partly of existing high-speed track between Minden and Berlin, but there are no further improvement plans on this corridor. Therefore this research is a first exploration on the possibilities for improvement of interoperability on this corridor. When designing solutions for the acceleration of rail passenger transport on this corridor, European regulations, such as the TSI should be taken into account. In the following chapter problems regarding the interoperability will be indicated and analyzed.



Figure 6: TEN-network (source: EC Mobility & Transport)

3. Analysis current issues

3.1 Introduction

As depicted in the chapter 2, international railway traffic brings along a series of problems that also apply to the Amsterdam Berlin corridor. These problems are divided into operational and technical problems. In this chapter the problems that occur on the Amsterdam – Berlin corridor will be outlined and explained in their context.

Technical problems arise with:

1. The difference in power supply
2. Different guidance- and safety systems
3. Track speed limit
4. Allowed train speed limit

Operational problems consist of:

5. Available concession space on the corridor
6. Language and knowledge of the train staff
7. Amount of integrated stops

3.2 Power supply

3.2.1 Historical context

To understand the differences in power supply between the Netherlands and Germany one should look at the history of railway traffic and in particular the development of the electrification of the European railway networks. This goes all the way back to the origination of the electrical motor and its capability's at that time.

With the invention of the electro-dynamic motor in 1866 by Werner von Siemens electric traction became available for the masses. With the coming of this electromotor two major changes occurred. First power supply was from that moment on not carried on the vehicle anymore, but supplied to it. Second the vehicles now would move themselves inside the power supply network. Engineers then had to face three questions that would decide the future of electric railway traffic. First; how is the power transferred to the locomotive? Second; what sort of power is best supplied? And third; what in vehicle motor is best used? (Dietmar & Hecht, 2008)

3.2.2 Power supply method

The first question proved to be the most simple to answer. The first electrical trains were supplied by using the rails as conductor. The dangers of this method soon became apparent as it was easy to contact the rails or cause short circuiting. Therefore it was concluded that a power supply system with an overhead and a pantograph would be preferable. This system is used almost everywhere in Europe, also in both Germany and the Netherlands and therefore does not cause any problems concerning the interoperability.

3.2.3 Development of the electromotor

The choice what sort of power to supply to the locomotives is one that heavily depends on what motor is used. At the time two types of motors were available, the DC serial circuit electromotor and the three-phase current electromotor.

The DC electromotor was at the time the right choice when it came to effective traction power. The advantage of using a DC electromotor was mainly the relatively small weight and size of the motor in comparison to a three-phase electromotor. The applied voltage for DC motors was relatively low, later on maximally 3000 Volts, which had one major disadvantage. When providing a high current at a low voltage resistance rises extremely. Therefore loss of power is high, the overhead for supplying DC needs to be larger and substations that supply the overhead need to be placed closer together. Also is there no possibility to deploy locomotives in series, due to the low voltage of DC power line that cannot supply enough power.

The three-phase current electromotor which uses alternating current (AC) was comparatively large and heavy, and wore out much faster than a DC motor. The most important advantages were the use of much smaller overhead wires and substations could be situated further out. The largest disadvantage of this system was the complexity of the overhead system with two separate wires and double pantographs that caused the production and maintenance costs to rise.

The breakthrough for a motor that didn't experience any of these disadvantages came when the use of AC power could be combined with a DC serial circuit electrical motor. This was made possible when rectifiers that could convert AC to DC became small enough to fit onto the train itself. It was too much to transform the 50 kV 50 Hz that is supplied by the electricity networks directly to DC, but when transformed to a lower voltage and frequency of approximately 15 kV and 16,7 Hz, it seemed possible. The choice of the system to be used in Germany then became quite apparent. From that moment was decided that the current supplied to the railway network should be 15kV with a frequency of 16,7 Hz. (Dietmar & Hecht, 2008)

In the Netherlands this choice was not as apparent, and was discussed extensively. While AC motors were very large and heavy due to the needed rectifiers, they were also subjected to much more wear. Therefore the Dutch did not simply take over the German system. Because distances in the Netherlands are relatively small, the fact that overhead for the use of DC is costlier and more substations are needed can be overseen. Another important additional advantage was that telephone lines running next to the railway track would not be disturbed by the magnetic field generated around low voltage DC lines, in comparison to the much stronger magnetic field created by high voltage AC. The decisive factor for the Dutch was the fact that workers could perform maintenance on the overhead when using isolated ladders with the power on, up to a maximum of 1500V. Therefore the Dutch railways decided that the network should be supplied with 1500V DC.

3.2.4 Network power supply

Throughout Europe similar choices were made such as in Germany or the Netherlands. In comparison to the unification of Europe in terms of the width of the rails, the used power supply system was not unified. This caused widespread differences between European countries and sometimes even in countries themselves. The current situation considering the power supply systems in Europe is depicted in Figure 7.

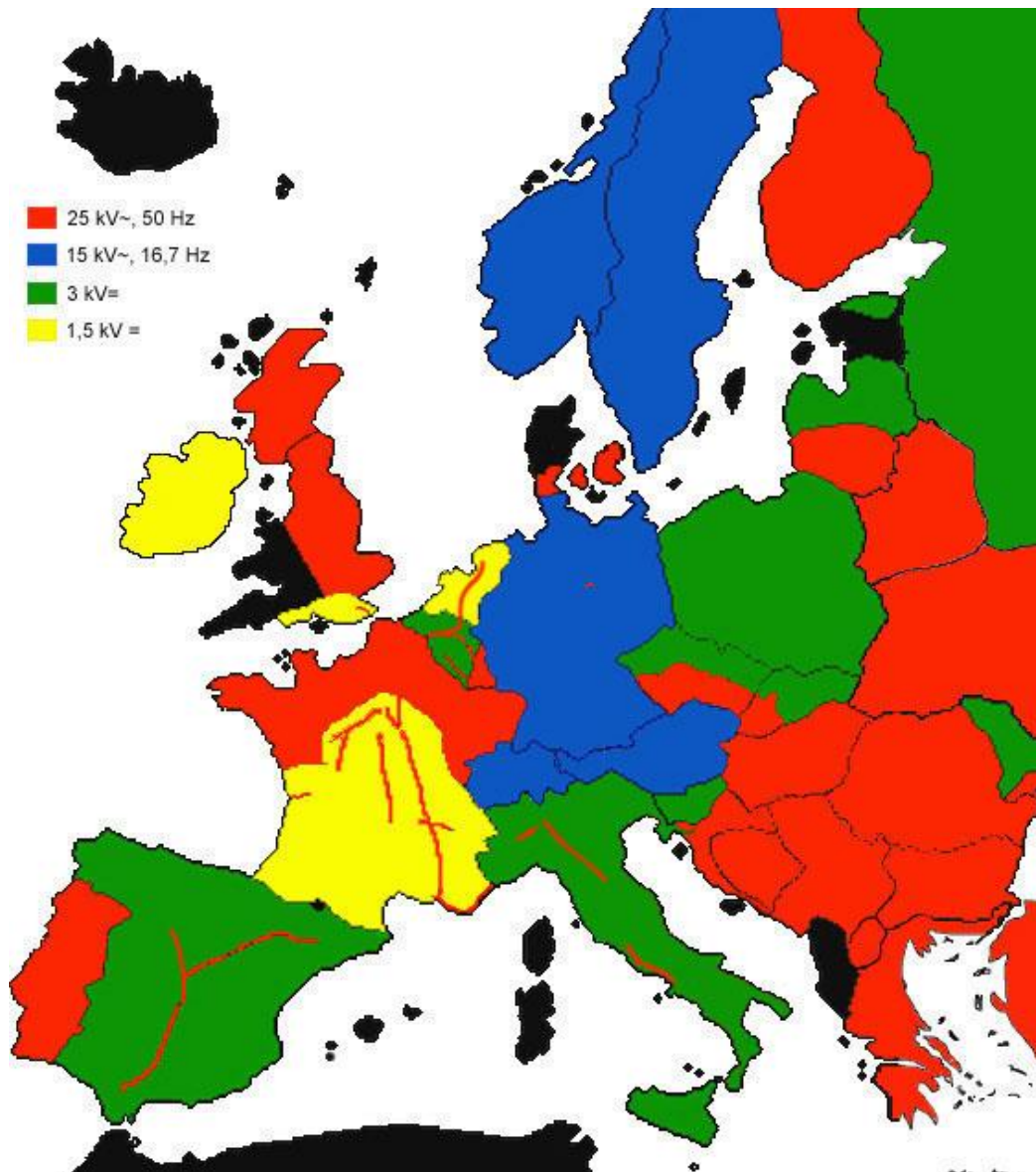

Figure 7: European power supply systems (Source: www.bahnstatistik.de)

The difference in power supply system's caused the isolation of each nationwide railway network from that of other European countries. Because each power supply system uses a different electrical motor that is not compatible with other supply systems, the passage of electrical trains from Germany into the Netherlands and the other way around is not possible. To overcome this problem the electrical locomotives can be changed at the border crossing or be pulled by the new generation of powerful diesel locomotives. On the Amsterdam – Berlin corridor the locomotive is changed at the German border station of Bad-Bentheim on a section where power supply can be changed accordingly.

3.2.5 Future developments

The latest projects that involve the construction of entirely new railway track are equipped with 25kV 50 Hz AC electrical power. The use of this current has numerous advantages. Where power supply with higher frequencies caused a serious problem in the past, today's generation of electrical engines can easily convert this high frequency and high voltage current. Another advantage of a 50Hz frequency is that the power fed to the railway overhead can be easily transformed out of the 50kV 50Hz power supplied by the electricity network. Also a higher voltage applied means less loss of power due to transport, and with the use of AC current locomotives can run in series. The major disadvantages of this power supply system exist in its incompatibility with other commonly used systems. Most available and applied train control systems are incompatible as well as most locomotives, equipped for regular power supply (Dietmar & Hecht, 2008).

As shown in Figure 7, 25kV 50Hz AC power is already in use in several European countries such as the northern United Kingdom, northern France, Portugal and a large part of Eastern Europe. The use of this power system in Eastern Europe can be explained by the fact that these railway lines were electrified relatively late in the 19th century when it was already apparent that 25kV 50Hz AC power would be the future of railway power supply. On several new high speed railway lines such as the TGV lines in France or HSL-south in the Netherlands and cargo lines such as Betuwe route this system is also applied. These corridors can only be used by trains that are compatible and are completely isolated from the rest of the nation's railway network.

3.3 Railway guidance- and safety system

3.3.1 Introduction

When railway transport became more popular, the capacity on the available railway lines needed to be increased. Normally only one or maybe two trains would operate a single railway line and were therefore not bothered with any other traffic on the same track. When capacity was raised by introducing multiple trains on a single track they were confronted with the problems of opposite trains and, later when differences in mutual speeds increased, overtaking. Therefore several primitive manual and visual signalling systems were developed to ensure a safe passage. As more and more trains were deployed to keep up with the growing demand more extended guidance- and safety systems were developed.

The development of railway guidance- and safety systems occurred somewhat the same way as had happened with the power supply. Each country developed its own system based on the applied power supply system and other influences such as the applied signalling systems, which were already distinctive. The current guidance- and safety systems consist of several systems both track- and train based that ensures the safe passage of a train. Track based systems are for example the “section clearance” notification, switch control and safeguarding, signalling and railway crossing safeguarding. Train based systems are cabin signalling, automatic drive and braking interface as well as compulsory emergency braking.

3.3.2 Railway signalling systems

At the beginning of the railway development signals for railway traffic were given by railway staff that each manned an individual signalling post. While this system of course very labour- intensive and uneconomical is signalling posts were replaced by mechanical signals that were operated from a distance so that one person could operate multiple signals. With the invention of new electromechanical and later on light signals distances from which signals could be operated grew, and with the use of internet they could be operated from anywhere on the world. Each individual country has its own railway signalling system that they developed over the years. This means that signalling systems also differ between The Netherlands and Germany (Fiedler, 1999).

In the early 20th century each railway company operated on its own track with its own set of rules and regulations and thus also an own signalling system. After the Second World War the Dutch regulations and signalling system were unified. Almost all the mechanical signals were replaced with light signals in the 80's and since 2004 have completely disappeared alongside the Dutch railways. In Germany on the other hand, the signalling system is not completely unified as is in the Netherlands. This has to do with the fact that the country is a lot larger and adjusting all signals costs more time and money. Another very important reason is of course the separation between east- and west-Germany that prolonged lasted until 1989. This caused the formation of two separate systems in east- and west- Germany that were united in the “Bahnstrukturreform” in 1993. In comparison to the Dutch system the German system is a lot more complicated and many mechanical signals are outdated.



Figure 8: left to right; Dutch main signal, German mechanical main signal including prior signal, German main light signal HI- type and German light signal Ks- type including prior signal (Source: www.stellwerke.de)

Because it is extremely difficult to read these signals at high- speed a new system was developed. In these most modern systems signals no longer stand beside the track but are integrated in the train driver's display. In Germany the Linien Zug Beeinflussung (LZB) train control system is used to transfer these signals from the track to the driver's display. The Dutch train control system Automatische Trein Beïnvloeding (ATB) cannot perform this function and therefore the European system ETCS is used for signal display on new high- speed railway lines in the Netherlands (Signalsysteme, n.d.).

When a train driver wants to operate in a country he must home the necessary knowledge of the rules, regulations and signalling system. This means that when a train driver wants to cross a border he must home the knowledge of both systems. Another very important fact is that each different safety- and guidance system depends on the applied signalling systems. The problems that arise here will be further explained in paragraph 3.3.3 (Pachl, 2010).

As mentioned in paragraph 2.2.4 the European Commission is working on a unified European signalling system called INESS. In the future all railway tracks that are indicated as TEN tracks, as is the Amsterdam – Berlin corridor, will be required to apply this system according to the TSI. Though this project is still being investigated it will be many years before it can be applied (Pachl, 2010).

3.3.3 Train control systems in Europe

To prevent trains from colliding when the train driver makes a mistake train control systems were developed to respond automatically in such a case. The first systems were already developed in the early 20th century that would operate by transferring a signal mechanically to the train and induce a response such as a requesting confirmation of the train driver or start an emergency brake sequence. Later on other methods were applied such as magnetic or electronic and more recently by an airborne signal. The speed which European countries implemented these systems was very differentiated, for example the German started relatively early with implementing a train control system and the Dutch only started after they were brutally confronted with the dangers when a major train disaster took place in the 1950's.

The variety of train control systems in Europe is displayed in Table 5. As can be discovered in the second column of the table the European train control systems are based on a large variety of techniques that are not compatible. In the third and fourth column of Table 3 is depicted which train control systems are applied on several sections of the Amsterdam – Berlin corridor. The differentiation of train control systems is a major problem when it comes to interoperability and international railway traffic. The German as well as the Dutch train control systems will be shortly explained to clarify why these systems are not compatible with each other.

Table 5: European train control systems (Dietmar & Hecht, 2008)

<i>Systems with point formed information transfer</i>		
System name	Transfer system	Land
Indusi, PZB90	Inductive resonance	Germany, Austria
Crocodile	Sliding contact	France, Belgium, Luxembourg
Signum	Magnetic	Switzerland
ZUB 121	Transponder, short loops	Switzerland
ZUB 123	Transponder, short loops	Denmark
TBL 1, TBL 2	Transponder	Belgium
KVB	Transponder	France
AWS	Magnetic	United Kingdom
ASFA	Inductive resonance	Spain
EBICAB 2	Transponder	Norway, Sweden
L 10 000	Transponder	Sweden
<i>Systems with line formed information transfer</i>		
System name	Transfer system	Land
LZB	Cable line conductor	Germany, Austria, Spain
TVM 300, TVM 430	Coded track circuit	France, Belgium
ATB	Coded track circuit	Netherlands
ACC 1, BACC 2	Coded track circuit	Italy

The in Germany applied train control systems can be divided into two types, as is depicted in Table 5. These types are the point based system and the line formed system. Of each of these systems several versions or variants exist that were developed throughout the years. The point based train control system (Punktförmige Zugbeeinflussung, PZB), consists of a trackside and train based electromagnet with which signals can be transferred. The more modern line based train control system (Linien Zugbeeinflussung, LZB) is a computer based system that constantly monitors the whereabouts of the train by sending and receiving data to cable lines between the tracks.

The Dutch train control system (Automatische Trein Beïnvloeding, ATB) has the same functions as the German LZB system but uses the conductivity of the track itself to transfer data. Due to the different data transfer methods, and moreover the completely different systems and regulations that control the train in case of emergency, these systems are not compatible with each other. More elaborated explanations as to how these systems were developed and the more specific inner workings, are given in Appendix B.

3.3.4 Development of train control systems

As described in paragraph 2.2.4 the European community has developed its own train control system called ETCS and is planned to be applied on all TEN marked railway tracks. At this date it is only scarcely applied throughout a couple of European tracks. In the Netherlands the Betuwe route freight railway line and the HSL south high- speed railway line are equipped with this system and in Germany several track sections such as the new high speed railway line Halle – Leipzig – Berlin (Panten & Gralla, 2007). The workings of ETCS are further explained in Appendix B.

Although a European train control system is available railway operators are reluctant to install it. The most important reason for this is of course the involved costs. The idea behind developing a unified European train control system was to improve market competition between suppliers and so drive back production costs in contrast to single suppliers of different systems that hold a monopoly. This unwillingness of the European railway operators has also to do with the fact that when an interoperable system is available they lose their own monopoly (Pachl, 2010). Applying strict regulations for the improvement of market competition by the European Union such as the TSI is necessary to implement such a major change in the European railway system (Heinisch, 2005). One future development that could force network operators to change the applied train control system is when producers stop supplying the old systems when it has become unprofitable. This is mainly the case for systems that are not widely applied such as the Dutch ATB system.

3.3.5 Train operating system

On board of the train all the information given by the train operation system needs to be processed and if necessary displayed in the driver's cabin. Behind each of the applied train control systems on the Amsterdam – Berlin corridor lays a different processing system, so to be able to operate on a track section the train needs to be equipped with the right system or with multiple. Next to the difference in power supply between the Netherlands and Germany this is an important reason why locomotives are changed at the border station of Bad Bentheim.

3.4 Speed limits

The allowed speed for a train depends on several properties that can be divided into track- and train properties. These properties are:

- The type of individual carriages
- The kind and length of the trains
- The braking properties
- The track properties
- The operational constraints

3.4.1 Track speed

Unfortunately the maximum speed on a railway track is not as unlimited as on the German Autobahn. Maximum speeds for railway traffic are tightly regulated because of the high safety risk. That is when something goes wrong it immediately endangers a large amount of people so a high level of safety needs to be guaranteed. A considerable case is that Germany uses railway track for mixed traffic. On a high- speed track both ICE trains and slower regional expresses and freight trains are allowed, a decision the government made when planning to build a high speed railway network. Therefore maximum speed is limited, unlike the French TGV system that is an independent network and has no involving in the regional and freight railway system (Fiedler, 1999).

Table 6: Track standards Germany (DB Netz AG, 2009)

Type	Speed level	Criterion
P 300	231 – 300	High- speed railway traffic
P 230	161 – 230	Fast long distance passenger traffic
M 230	161 – 230	Mixed traffic
P 160 I	121 – 160	Fast long- and short distance passenger traffic (120 trains/h)
P 160 II	121 – 160	Fast long- and short distance passenger traffic (60 trains/h)
M 160	121 – 160	Mixed traffic
G120	81 – 120	Cargo traffic
R 120	81 – 120	Short distance passenger traffic
R 80	51 – 100	Short distance passenger traffic
G 50	50	Regional cargo traffic

In Table 6 the different track types available in the German network are displayed with their corresponding criteria and speed indication levels. The maximum allowed track speed for each section of the Amsterdam – Berlin corridor is shown in the second column of Table 3. The variation of maximum speeds can be explained by several track properties. Establishing the maximum speed depends on the inclination of the track, the change in inclination, the curvature and the tilting of the track. Other limitations are the distance between two tracks, which is important due to air pressure of oncoming trains at high speeds, the type of overhead used, because at higher speeds a stronger overhead is demanded, or the size of tunnels and the presence of railway crossings.

These limitations show clearly in the differences between track upgrades or newly build track, two methods that are commonly used in Germany to raise travelling speeds. While upgraded track section used to be normal track, rails are often placed closer together and also tunnels and other rail side structures are not built accounting for higher speeds as well as its curvatures and inclination or declination levels. When building a new track all these limitations are of course dealt with in the design which allows for much higher speeds, only of course when the landscape allows for such measures to be taken (Fiedler, 1999).

3.4.2 Train speed

Besides that the maximum velocity on the track is limited, also the trains that operate on it have limitations. This of course has to do with the power that the electric motor can transfer to the rails, but also with how fast it can come to a stop again. For acceleration it is very important if the train is pulled by a traction locomotive or that several axes throughout the length of the train are driven. A locomotive of course has only a limited number of axes with which it can transfer the power onto the rails but more important is are the forces that arise in the couplings. These couplings don't have unlimited strength and therefore the force with which the carriages can be pulled has a maximum. Here the length and the weight of the train play a major role as when more carriages or heavier ones are linked forces on the locomotive coupling rise.

Braking properties are the more important case when it comes to train control and safety. Braking properties depend on several factors such as length and weight of the train and several others. The distinction between pulled carriages and a composite train is less while it is common that each carriage is braked individually on safety grounds. Of course there is still a difference in the type and amount of breaks applied that make a difference in the braking properties of a train. For each train

combination that operates on the European railway network braking properties are tested and its braking path calculated and fixed into a braking curve. As explained in 0 these braking curves are stored on the board computer of a train and based on these curves the train control system guards the safety of the train. Together with acceleration these train properties form the basis for the allocated maximum speed.

The trains with pulled carriages that operate on the Amsterdam – Berlin corridor are in Germany pulled by a very powerful locomotive which makes high speeds possible. Because the carriages are pulled, which causes a standard safety risk at high speeds, and more importantly are not pressure tight the maximum speed is limited 200 km/h. Above 200 km/h carriages need to be airtight because of the pressure that arises when to high- speed trains come on to each other in a tunnel which can cause passenger injuries. In the Netherlands the main reasons for the limitation of the maximum speed to 130 km/h are the type power supply and the overhead properties. A train that uses DC power supply with a relatively low voltage such as in the Netherlands can only supply a limited amount of power. Furthermore the overhead lines are not built for high speeds, while it causes them to vibrate and even break which proposes a possible safety risk.

3.5 Operational constraints

3.5.1 Line Stops

Every stop costs time, that is; a train is always faster when it continuous with its original speed than when it has to brake to a halt, stop at a platform to load and unload passengers and afterwards accelerate back up. It is therefore an important that every stop is worth stopping and thus a relevant number of passenger wishes to get on or off the train at that stop. In Table 7 an indication is given of the track length and the time an IC train needs to fulfil one stop. The numbers in this table originate from an ICE 3 type train, which does not operate on the Amsterdam – Berlin corridor, though these numbers can provide a useful indication. The train that operates on the Amsterdam – Berlin corridor is expected to have at least similar values for braking, it will take a little longer to accelerate while the carriages are pulled by a single locomotive and of course it won't reach speeds above 200 km/h (Mnich, 2006).

Table 7: Stopping times for a ICE type 3 (source: Institut für Bahntechnik)

Speed (km/h)	150	200	250	300
Length (km)				
Accelerating	1.9	4.3	8.9	17.9
Braking	1.7	3.1	4.8	6.9
<i>Total length needed per stop</i>	3.6	7.4	13.7	24.8
Time (min.)				
Accelerating	1.4	2.2	3.4	5.4
Braking	1.4	1.8	2.3	2.8
<i>Total time needed per stop</i>	2.8	4.0	5.7	8.2
<i>Per stop including 2 min. stopping time</i>	4.8	6.0	7.7	10.2
<i>Time passing through without stop</i>	1.4	2.2	3.3	5.0
<i>Loss of time per stop</i>	3.4	3.8	4.4	5.2

One problem that also has to be taken into account is that while passing a station directly maximum speed is reduced. There are of course exceptions where platforms can be passed at full speed but they are uncommon. In Germany smaller stations often have a detached track that has no platform and thus maximum speeds are allowed. In the Netherlands this method is not applied and allowed speeds at regional stations is mostly 80 km/h and 40 km/h at the IC stations also due to the presence of switches. This also causes the time to rise it takes to pass through without stopping and therefore should be noted when removing a stop from the timetable.

3.5.2 Concession space

In the Netherlands as well as in Germany a large number of travellers use the public transport system. This has caused the railway operators to deploy as many trains on a single piece of track as possible. Several sections of the Amsterdam – Berlin corridor are extremely busy and therefore have very little room to manoeuvre in the timetable.

In the current schedule on the Amsterdam – Berlin corridor several measures have been taken to overcome this problem with limited concession space. As revealed in chapter 2.1.1 the international train from Amsterdam to Berlin used to operate in the Netherlands as an independent train but was adopted in the nations IC schedule so the remainder of this concession space would come available. Because the IC that the international train replaces is scheduled to ride every 30 minutes, the international train can be planned during any of the IC trips. This proposes a major advantage while the train can be planned more often without occupying any concession space. In Germany the same case applies for available concession space so that planning has become a difficulty. In the current schedule an extra stop is integrated in both Bad Oeynhausen and Bunde where the train needs to wait for higher priority trains to pass.

3.5.3 Train staff

As the IC Amsterdam – Berlin arrives in the border station of Bad Bentheim it stops for a longer period of time to change locomotives. The length of this stop is also used to change home staff so that Dutch staffs operate on the Dutch section and a German staff on the German section of the corridor. This has two reasons; first the on board staff needs to home the spoken language and have certain knowledge of the corridor. Second the train operator needs to be educated in the applied train operating and signalling system as well as applied rules and regulations. This at itself is not a problem, the problem only arises in the case that this lengthy stop is no longer necessary due to the application of any solution variant that eliminates the need for a change of locomotives. Only then a change of staff causes an unwanted stop and thus a loss of travel time.

The border station of Bad Bentheim is a very small station, at which only very few passengers get on or off the train. In a normal IC schedule this stop would not be integrated while passenger generation is too little. Only because of the available facilities to change locomotives this stop is integrated in the Amsterdam – Berlin corridor. When these facilities are no longer necessary the stop will almost certainly be removed out off the schedule. Changing the train staff then becomes a problem.

4. Generating solution variants

4.1 Introduction

After studying the problems that induce a loss of travel time on the Amsterdam – Berlin corridor solution variants can be generated based on these findings. As applied in the problem analyses they will be divided into technical and operational solutions. The technical solutions can further be divided into train based and track based solutions. Train based means that the generated solutions will only affect the train, i.e. the locomotive and its carriages and the same applies for track based solutions that will affect the track itself, its overhead and other additional systems. The division of these solutions will be important later on in the research when solution variants need to be combined to get the desired outcome.

4.2 Track based technical solution variants

4.2.1 Track upgrade

Each section of track has its own maximum allowed speed based on the building properties. In the second column of Table 3 maximum speeds of railway sections are shown for the Amsterdam – Berlin corridor. These maximum speeds are derived from the track properties, so when an increase in speed is desired one option is to alter the properties of the already existing track, or simply put a track upgrade. Between Minder – Hannover – Berlin the track is already upgraded or newly built so does not need to be considered anymore. Only little room for improvement is left between Minden and the Dutch border, where a maximum speed of 160 km/h is applied, though the most profit can be achieved in the Netherlands where the maximum applied speed is only 130 km/h.



Figure 9: Track upgrade Hamburg - Berlin (source: Bahn im bild)

4.2.2 Construction of new high-speed track

To achieve higher speeds not only can the existing track be upgraded, also a complete new stretch of railway can be built with even better properties and thus a higher maximum allowed speed. To be able to construct a new piece of track there needs to be enough land available, which especially in the Netherlands where free space is a rare, becomes extremely difficult. Though they succeeded to build the HSL- south it did not quite go as planned and a lot of opposition has come up. Therefore the project for the planned HSL- east, which would run from Amsterdam – Utrecht – Arnhem – Frankfurt, was abandoned. Therefore it is absolutely not realistic to want to realize a completely different stretch of high- speed railway line in the Netherlands than the original plans that were abandoned

(Baggen & Vleugel, 2008). In Germany the possibility remains to build a new stretch between Minden – Osnabruck and perhaps further to Rheine, but it would be highly unlikely that building this track will be economical. This is because no other major railway corridor uses this track section and mostly serves regional railway lines.



Figure 10: High- speed railway track Hannover - Berlin (Source: Bahn im bild)

4.2.3 Conversion power supply

For overcoming the differences in power supply by changing track based installations there are several solutions available, with each their own disadvantages. The first two are respectively equipping the entire corridor with the Dutch 1500 V DC system or with the German 15 kV 50 Hz AC system. As described in paragraph 3.2.3 both systems have their disadvantages, and for both countries it would be highly undesirable to just convert one single corridor a different power supply system that cuts of the rest of the country its railway network. This of course does not improve the interoperability for the network as a whole. The main problem remains with 1500 V DC because it has a limited maximum speed that can be achieved of 160 km/h. For example supplying with 25kV 50Hz AC does not have this speed restriction and is advisable to use when building new or upgrading track because it is the most profitable in terms of travel time reduction.

Another possible solution is to convert the network power supply to 25 kV 50 Hz AC, which has a lot less disadvantages than both other applied systems. In France it is already applied on all the high-speed railway lines and in the Netherlands on HSL- south and the Betuwe route. Investment costs of converting the power supply are very high and when converting just this single corridor interoperability would only deteriorate. When applied in combination with the build of a new separate high- speed railway corridor or when applied to the entire network it would be profitable for the interoperability.

4.2.4 Train control systems

To overcome the problems between different train control systems there is of course, just as with the power supply, a possibility to apply one of the used systems on the entire corridor. While PZB and ATB don't work with speeds over 160 km/h they will cause an increase of travel time, but also when applying LZB that has no speed restrictions, interoperability will suffer on a network scale. A better solution would be to immediately apply ETCS because this system is set as European standard and throughout the distant future will be applied to the entire European railway network.

To overcome the lack of interoperability due to use of different train control systems for other trains that use sections of the same corridor it is possible to install the new train control system next to the already existing system. ETCS has a compatibility build which allows it can coexist next to other applied train control systems. The level of ETCS to be installed would be ETCS level 2 or higher, otherwise cabin signalling would not be available which means no speeds higher than 160 km/h. The application of different levels isn't a problem while the ETCS level can be changed during operation which allows countries to choose which level of the system to apply (Pachl, 2010).

4.3 Train based technical solution variants

4.3.1 Train speed upgrade

The train that currently operates the Amsterdam – Berlin corridor with its pulled carriages is not allowed to reach speeds higher than 200 km/h, so when the track allows for a higher speed it still will only go 200 km/h. When achieving higher speeds is desired a composite train needs to be deployed, for example the German ICE or the Dutch/French Thalys. This means new trains need to be purchased, which would be most profitable if the majority of corridor will be upgraded to accommodate speeds up to at least 200 km/h.

4.3.2 Conversion power supply

When the power supplied by the overhead is changed the locomotive used needs to be compatible with this system for which new locomotives need to be purchased. Without a conversion of the supplied power there is another solution to overcome the incompatibility between the Netherlands and Germany, which is using multiple system- locomotives. On board of these locomotives power can be transformed accordingly, for which there are extra installations on board. This system is already applied on the ICE 3M that operate on the Amsterdam – Frankfurt corridor, where it was originally meant to operate on HSL- east. Another example is the Thalys that operates between Amsterdam – Brussels – Paris, which is compatible with three different power supply systems. The last solution that can be considered is the use of diesel locomotives, which do not use the overhead power supply. While these trains are not as energy efficient as normal electrical trains operation costs are higher.

4.3.3 Train control and operating systems

When one single operating system is applied to the entire corridor the trains that use it need to be equipped accordingly. To avoid inverting in trackside changes equipping locomotives with multiple train control systems is also a possibility. As happens with the power, the ICE3M and Thalys are also equipped with the several train control systems that are applied on corridors which they operate on. An example of multiple train control systems applied on one locomotive is shown in Figure 11. In comparison to making track side changes, applying multiple systems to one locomotive is less costlier. But because in the near future ETCS will become the standard applied train control system, first in the Netherlands and on long term also in Germany, it is advisable to consider this development when making investment decisions.

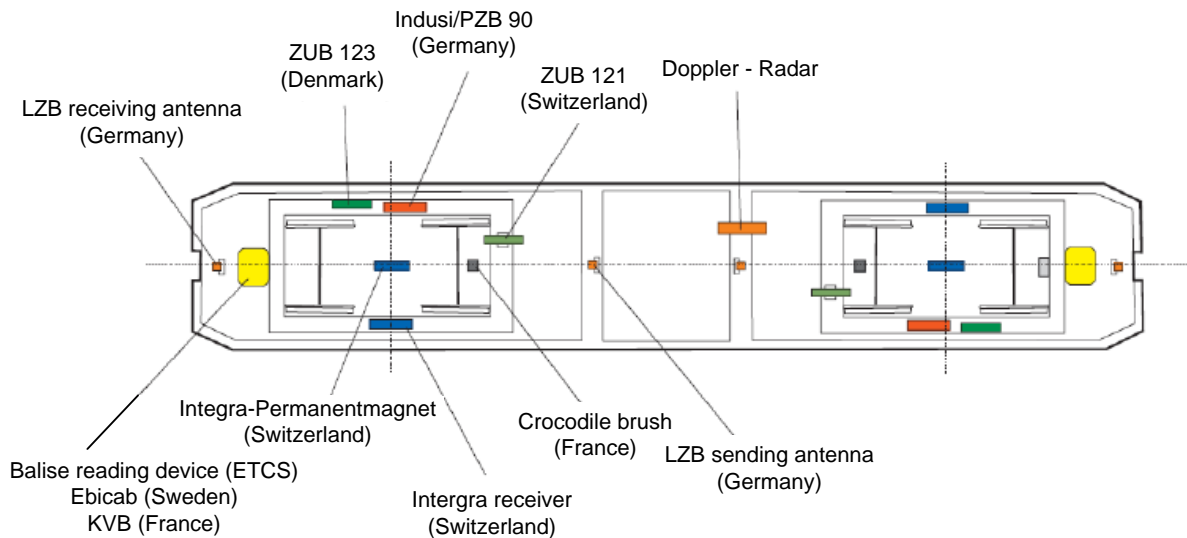

Figure 11: Example of a locomotive with multiple train control systems (source: ETR 11/2000)

4.4 Operational solution variants

4.4.1 Reduction amount of stops

Each stop that a train makes costs time, as is depicted in Table 7 so travel time can be reduced simply by fewer stops. This means devising a new schedule that is independent of nationally scheduled trains and can therefore move more freely. There should always be stopped at major hub stations to guarantee connections to other parts of the country. Stopping only at major hubs would be consistent with the schedule properties of an ICE. Depending on the amount of travel time reduction desired to achieve by reducing stops, they can be reduced in greater or lesser extent.

The decision which stops to eliminate depends on two criteria, the travellers demand that a stop generates and the hub functions that a stop fulfils. A stop which generates a high traveller's demand guarantees a high rate of return and should therefore be adopted into the schedule. A hub station also supplies a large number of transferring passengers and will therefore improve accessibility and traveller demand.

4.4.2 Subsequent staff training

As described in paragraph 3.5.3 train staff is required to change at the border crossing to ensure there are always national staffs on board with the knowledge and expertise to serve in the travelling country. In case the border stop is no longer necessary, the change of train staff needs to be achieved otherwise. Changing staff can be shifted to another station, or be eliminated completely.

On most international high-speed railway lines onboard staff is not changed at border crossing but instead operates on the entire line. An example is the ICE from Amsterdam to Frankfurt (Main). This is possible when the staff is multilingual and has the appropriate knowledge of the entire corridor and the train operator is schooled in both operating and signalling systems. Therefore subsequent staff training and the use of multi-lingual's can make a border stop unnecessary. This can of course be applied on both Dutch and German staff.

4.5 Solution scenarios

The generated solution variants mostly don't book any profits in the reduction of travel time when they are applied without any other measures. To make these generated solutions effective they can be combined to form scenarios that induce the desired amount of reduction in travel time. Three different scenarios will be proposed varying from low cost, low effectiveness to high cost, high effectiveness solution scenarios.

4.5.1 Low-end solution scenario

The easiest way to reduce travel time is a solution in the operational sphere, which is simply reducing the amount of stops. This solution in itself costs nothing, nothing additionally. Two points that do need to be accounted for, one is that when a train makes fewer stops it has to attract the amount of passengers on fewer stops. The second is that when the schedule is detached from the national IC schedule it needs an own time slot, which is difficult to achieve on highly occupied track sections. So the low-end solution variant would be:

- Reducing the amount of stops, detaching it from the IC schedule in both the Netherlands and Germany

4.5.2 Intermediate solution scenario

The reduction of the amount of stops does not improve interoperability itself; to achieve this, other investments need to be made. As explained improving only part of the interoperability won't reduce the travel time, only a combination of interoperability improving measures. The major bottleneck on the Amsterdam – Berlin corridor is the border crossing, where power supply, train operating and control system and staff change force the train to stop for a longer period of time. This stop can be avoided by deploying multiple systems locomotives and training the train staff. Purchasing entire trains that can also reach higher speeds is not necessary while this could only be applied on the Hannover – Berlin section, which in itself is not likely to be profitable. So the intermediately radical compilation of measures will be:

- Reducing the amount of stops to an ICE schedule
- Deploying multiple power and control system locomotives
- Subsequent staff training

4.5.3 High-end solution scenario

When major additional funding is available a more elaborate package of measures can be applied. The most viable would be a track upgrade on the sections where the travel time can be reduced most. That means on the entire Dutch section of track an upgrade to 160 km/h up to Rheine where 160 km/h is already allowed. The construction of entirely new track is highly unlikely to be profitable and therefore renounced. An upgrade to 200 km/h is also a possibility, then including the German section up to the connection with the existing track upgrade at Minden. This possibility will be reserved for when an upgrade to 160 km/h appears not to be sufficient.

To improve operability for the entire network it is recommended to apply not only the countries own train control systems, but additionally ETCS. This investment mainly focuses on future developments in applied train control systems because it could possibly save further future investments for train control systems. Furthermore the same measures as with the intermediate variant are applied to achieve the wished results in travel time reduction. So the measures for the high end scenario come down to:

- Track upgrade Amsterdam – Rheine to 160 km/h
- Track based control system double equipped with ETCS
- Reducing the amount of stops to an ICE schedule
- Deploying multiple power system locomotives
- Subsequent staff training

4.6 Effects

The effects of the solution scenarios can be compared with three indicators; the achieved reduction in travel time, the passenger growth and the costs of implementation. In this paragraph each of these effects are analysed for the created scenarios. The results of these analyses will be used for a short cost benefit analysis, based on which conclusions and recommendations can be made.

4.6.1 Expected reduction of travel time

To get an impression how much travel time is reduced due to the implication of the compiled measures calculations can be made. The results of these calculations are summarized in Figure 14. In this figure the most important stations with a hub function for providing transfer possibilities, where the train is most likely to stop are depicted with the large gray blocks. The remainder of current stops is depicted with a small circle. In between the grey blocks travel total travel time of each block is displayed. These numbers are the indication for the effectiveness of the implicated measures. As a comparison firstly the current situation is depicted on the top line of four. The second line suggest the low-end variant, the third the intermediate and the last line the high-end variant.

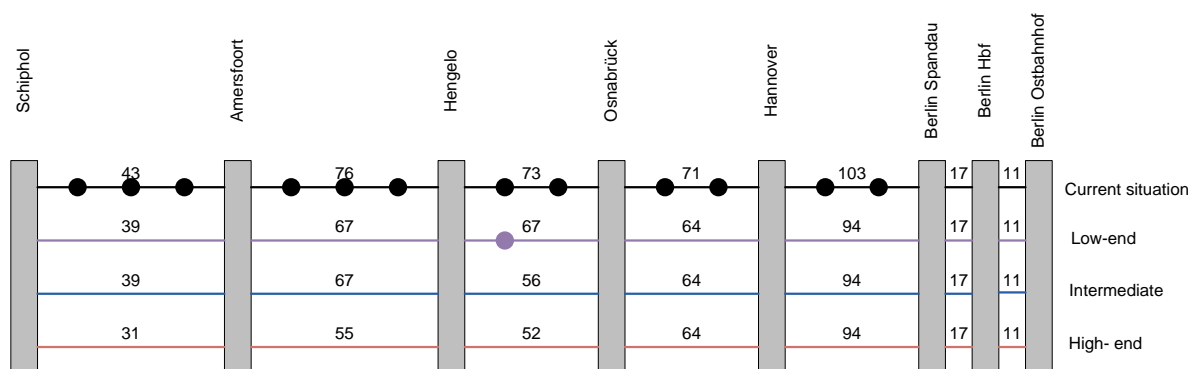

Figure 12: Expected travel time with the implication of several solution variants (own calculations)

Currently the train on the Amsterdam – Berlin corridor has a total travel time, from beginning to end, of 413 minutes, which is 6 hours and 53 minutes. The first variant with lesser stops only still stops on the most important stations and of course the border station where it still changes locomotives and staff due to the lack of interoperability. In this situation the expected total travel time is approximately 367 minutes, which is 6 hours and 7 minutes. This is a reduction of travel time of 46 minutes in comparison with the current situation.

The difference in travel time for the second variant lies in the improvement of international interoperability, here achieved by deploying multiple system locomotives. That means that the only additional reduction takes place at the border crossing. This stop is now eliminated and provides a reduction of 11 minutes. This brings the total travel time of the intermediate variant to 356 minutes, which is 5 hours and 53 minutes. The high-end variant has its additional effects on the Dutch section of the corridor where travel speed is now upgraded to 160 km/h. The total travel time for this variant is approximately 332 minutes, which is 5 hours and 32 minutes. This means the track speed upgrade provides an additional travel time reduction of 24 minutes.

4.6.2 Expected passenger growth

To make an estimate of the passenger growth, travel time elasticity will be used together with the obtained current passenger data (Table 4, Paragraph 2.1.3). To obtain the travel time elasticity, two sets of data are required where the difference in travel time can be compared. Unfortunately only the collected data of the current situation is available, therefore a solution must be found. Cuoto & Graham (2008) have researched a great number of European railway projects and concluded that when introducing a new high speed railway line, passenger numbers grow with an average of 8%. By creating an extra fictional scenario where a new dedicated high speed railway line is introduced on the Amsterdam – Berlin corridor passenger estimates can be made using the average growth percentage calculated by Cuoto & Graham (2008).

It must be said that this method has a large error, whereas the number used is calculated with data from several European countries. More ideal would be data specifically for the Netherlands or Germany, or even better, the Amsterdam – Berlin corridor. Though it has a predetermined error, this assumption is the closest estimation with the available data. Also calculating just these estimates only gives an impression of the passenger numbers at the border crossing, but passengers travelling nationally aren't accounted for. The train occupancy on the Amsterdam – Berlin corridor in the current situation with just international passengers is almost 20%. For a regular train service occupancy is average 30% (NS year report 2007). Therefore it can be reasonably assumed that occupancy on the Amsterdam – Berlin corridor, including national passengers, also has a total occupancy of approximately 30%.

For the fictional high speed railway line scenario passenger numbers are calculated. In this fictional scenario trains will have a maximum speed of 250 km/h, which brings the total travel time from Amsterdam to Berlin to 195 minutes. Now travel time elasticity (E_t) can be calculated dP/dt , where dP is the change in passenger numbers and dt the change in total travel time (Ortúzar & Willemsen, 2006). It is assumed that the travel time elasticity is linear. When the travel time elasticity is calculated the expected passenger growth for each of the proposed solution scenarios can be calculated. The results for yearly totals and growth percentages are displayed in Table 8.

Table 8: Passenger growth numbers for international passengers on the Amsterdam – Berlin corridor

Scenario	Expected passenger growth	Total expected passenger numbers per year	Percentage passenger growth
Low-end			
Amsterdam – Berlin	6644	400244	1.69 %
Berlin - Amsterdam	6914	416514	1.69 %
Intermediate			
Amsterdam – Berlin	8233	401833	2.09 %
Berlin - Amsterdam	8568	418168	2.09 %
High-end			
Amsterdam – Berlin	11700	405300	2.97 %
Berlin - Amsterdam	12175	421775	2.97 %
Fictional full high speed (control)			
Amsterdam – Berlin	31488	425088	8.00%
Berlin - Amsterdam	32768	442368	8.00%

4.6.3 Cost of implementation

The proposed improvements on the Amsterdam – Berlin corridor do not come without a price. In this section an indication of costs for each of the measures and finally an overview of the estimated investment cost and yearly operating costs.

When altering the schedule and separating it from regular IC service, a new purely international service is called to life. This means that, with a frequency of eight times per day, an extra train service is supplied. This additional service brings along extra operating cost that would otherwise be compensated by the fact that the line also serves as an IC. The operating costs exist of exploitation or vehicle cost, kilometre costs and service hour costs (Centrum Vernieuwing Openbaar Vervoer, 2005).

Vehicle costs are approximately 300.000 euro per train per year (CVOV, 2005), which results to a total of eight trains costing 2.4 million euro's a year. Kilometre cost amount to approximately 15 euro per kilometre (CVOV, 2005), with a trip length of 650 km, two directions, eight times per day, 350 days per year, which result in 54.6 million euro per year. Service hour costs are for an international train that uses specially trained personnel are an estimate 350 euro per service hour (CVOV, 2005). The yearly total service hour costs differ per scenario, because of the achieved differences in travel time. Therefore separate calculations are made for the current scenario, the low-end, intermediate and high-end scenario. The total yearly service hour costs for the current scenario are 350 euro per hour, for 413 minutes per trip, two directions, eight times per day, 350 days per year which amounts to 13.9 million euro. For the low-end scenario the trip length is 367 minutes, intermediate 356 minutes and high-end 332 minutes what results to yearly total service hour costs of respectively 12.3, 12.0 and 11.2 million euro. So a faster service has less service hours and is therefore cheaper in exploitation. All three operational costs for each of the scenarios is also summarized in Table 9.

Table 9: Summarized yearly operating costs

Scenario	Exploitation costs (million euro/year)	Kilometre costs (million euro/year)	Service hour costs (million euro/year)	Total operation costs (million euro/year)
Current	2.4	54.6	13.9	70.9
Low-end	2.4	54.6	12.3	69.3
Intermediate	2.4	54.6	12.0	69.0
High-end	2.4	54.6	11.2	68.2

Purchasing new rolling stock brings along one time investment costs, whereas maintenance is already accounted for within the operating costs. In the proposed intermediate and high-end solution scenario's it was assumed that only the pulling locomotive would be replaced with a multiple systems locomotive. For indication the price of a multiple system Bombardier TRAXX locomotive is used (www.bombardier.com). The purchase cost of a TRAXX locomotive is approximately 13 million euro, for eight new locomotives which add to a total of 104 million euro.

It is also possible to purchase entire new trains, not just the locomotives. For indication a Siemens ICE 3 unit costs approximately 30 million euro (www.Siemens.com), of which two units are required to form an entire train. The total cost for replacing the current rolling stock would then be 480 million euro. Though this is far more expensive than just replacing the locomotives, it has a couple of advantages. Additional rolling stock needs to be deployed to fill the gaps left in the regular IC schedule. These costs are not included in the costs to operate the Amsterdam – Berlin corridor but will still have to be taken by the railway operators. Furthermore Cuoto & Graham (2008) state that when major speed improvements are made without introducing new rolling stock, the increase in demand can be more difficult to identify. This can always be decided when introducing this measure, but for this paper the purchase of just multiple systems locomotives is used as the indicator number.

When building new or upgrading rail infrastructure there are several sorts of costs that have to be accounted for. The three major types of cost are: Planning and land costs, infrastructure building cost and superstructure cost (Campos et al, 2006). To make an estimation of the cost that will be generated by upgrading part of the Amsterdam – Berlin corridor average figures are obtained from literature. The research of Campos et al. (2006) resulted in key figures for building costs of high speed rail in several European and Asian countries. These figures do not include planning and land cost because these are unique to each individual project. This does not propose a problem because for a track upgrade land cost is not relevant for it is realized on already existing infrastructure.

Average building cost per kilometre for the Netherlands is an impressive 43.7 million dollar, whereas for Germany this is only 19.3 million (Campos et al, 2006). This difference can be explained by the fact that in the Netherlands the high-speed track is build separately from the conventional network, while due to high population densities the available space is scarce. Because the Amsterdam – Berlin corridor already exists, it can be assumed that it is more likely that the cost of upgrading a section of this corridor lies more in the price range as is the case in Germany. Therefore the indicator figure for the upgrade of the Amsterdam – Berlin corridor will be 19.3 million dollar per kilometre. The section to be upgraded, Amsterdam – Rheine, has a total length of almost 200 kilometres, which brings the total investment for a rack upgrade on this section to approximately 3.9 billion dollar or 2.9 billion euro’s. Maintenance cost is not included in this calculation but is assumed to be somewhat higher in comparison with conventional track. The costs for the implementation of the new ETCS safety- and guidance system are assumed to be included.

The investment- and yearly operating cost for the current situation and each of the solution scenarios are summarized in Table 10. In this table the operational cost for the current situation is placed between brackets because the other operating cost indicates what will be spent additionally. This is the approximate cost to operate the IC in the gap left in the schedule when separating the Amsterdam – Berlin line from regular service.

Table 10: Overview investment- and operational costs per scenario

Scenario	Investment cost (million euro)	Operating cost (million euro/year)
Current	0	(70.9)
Low-end	0	69.3
Intermediate	104	69.0
High-end	2900	68.2

4.6.4 Cost benefit analyses

To analyse the results and compare the created scenarios a cost benefit analysis can be performed. In the analysis the yearly costs are plotted against the yearly passenger numbers which then show the cost per additional passenger. Because the costs obtained are both onetime investment costs and yearly operational cost, it has to be transformed to total yearly cost. Therefore the investment costs are discounted to yearly expenses. It is assumed that the investment in rolling stock has a life span of 20 years, and the investment in infrastructure 50 years. The total yearly costs, the passenger growth number and the corresponding cost growth ratios are displayed in Table 11. The cost/growth ratio simply tells for each solution scenario how much it costs to gain one extra passenger. In the table can be seen that the low-end scenario is the most cost effective.

Table 11: Scenario cost/growth ratios

Scenario	Total yearly cost (euro)	Passenger growth (Actual numbers)	Cost/growth ratio (euro/passenger)
Low-end	69.300.000	16335	4242
Intermediate	74.200.000	16400	4524
High-end	184.200.000	16541	11136

5. Conclusions and recommendations

5.1 Conclusions

The main objective of this research was to explore the possible solutions and provide recommendations for the reduction of travel time for rail passenger transport on the Amsterdam – Berlin corridor. In the course of this research the current problems on the Amsterdam – Berlin corridor that result in a possible loss of travel time have been identified and explored. For each of these problems several solutions have been devised, put together in three solution scenarios and effects determined to accomplish the goals set.

From this research several key problems emerged that induce a loss of travel time on the Amsterdam – Berlin corridor, which can be divided into both technical and operational. The most important technical problems appear to be the differences between the Netherlands and Germany in power supply, signalling, operating and train control systems, which all involve the interoperability of the European railway network. The operational restriction that causes the major part of loss in travel time is the amount of stops on the corridor. Also staff training plays a small role in combination with the technical problems.

The complete overview of solution scenarios their respective travel times, the reduction of travel time they induce, the estimated passenger growth, the corresponding costs and the cost/growth ratio are displayed in Table 12.

Table 12: Overview devised solutions and their effects

Scenario	Measures	Total travel time	Traveltime reduction (min)	Estimated passenger growth	Cost (million euro)	Cost/ Growth ratio
Current	<ul style="list-style-type: none"> None 	6h 53m (413 min)	-	-	-	-
Low-end	<ul style="list-style-type: none"> Reducing the amount of stops, detaching it from the IC schedule in both the Netherlands and Germany 	6h 7m (367 min)	46	1.69%	69.3	4242
Intermediate	<ul style="list-style-type: none"> Reducing the amount of stops to an ICE schedule Deploying multiple power and control system locomotives Subsequent staff training 	5h 56m (356 min)	57	2.09%	74.2	4524
High-end	<ul style="list-style-type: none"> Track upgrade Amsterdam – Rheine to 160 km/h Track based control system double equipped with ETCS Reducing the amount of stops to an ICE schedule Deploying multiple power system locomotives Subsequent staff training 	5h 32m (332 min)	81	2.97%	184.2	11136

From the results can be concluded that the goal of reducing the travel time on the Amsterdam – Berlin corridor to less than 5 hours is not realistic. Even the high end variant only reduces travel time to roughly 5 ½ hours, which means that to reduce travel time to under 5 hours almost the entire corridor needs to consist of high- speed railway track. The conversion of the entire corridor to e new build separate high-speed railway track was deemed highly unlikely and therefore abandoned.

The most cost effective variant according to the cost/growth ratio would be the low-end scenario. But with a cost of 4242 euro per gained passenger it remains a large investment which doesn't earn itself back. Because total occupancy will remain approximately 30%, the costs of the low-end and the intermediate scenario are probably still covered by the revenues. Only the high-end scenario seems highly unlikely because it simply returns to little profit for the investments that must be made. Depending on the wishes of the transportation companies, both the low-end and the intermediate scenario are recommended.

Although the data shows that making no investments at all would be the most profitable decision it is still recommended to adopt at least the intermediate scenario. The trend of internationalization is rapidly proceeding, especially in the railway market. It is wise to invest now in faster and better international railway connections only to benefit from these investments in a much later stage. A better high-speed railway network can provide a powerful incentive for the future economic growth of The Netherlands, Germany and Europe.

5.2 Recommendations

In the course of this research not every relevant aspect to the subject of the Amsterdam – Berlin corridor could be investigated. This research has had its focus on the identification of problems and generation viable solutions for them. The estimation of passenger growth numbers is done relatively rough, because of the unavailability of real data on the Amsterdam – Berlin corridor. More accurate estimations can be made by the operators themselves, using a different approach and more reliable sets of data.

A very narrow scope has been adopted which allowed solutions only to be executed on the Amsterdam – Berlin corridor itself. For an operator it is more likely to view it on a network level and integrate projects and solutions to reduce costs. When implementing one of the devised scenarios on the Amsterdam – Berlin corridor integration should be considered.

Literature index

- Baggen, J. & Vleugel, J. (2008). *Een aanzet tot een netwerkvisie voor de hogesnelheidstrein van, naar en in Nederland*. Retrieved June 8, 2010, from Technische Universiteit Delft, Colloquim vervoersplanologisch speurwerk website: http://www.cvs-congres.nl/cvspdfdocs/cvs08_74.pdf.
- Campos, J., Rus, G. de, & Barrón, I. (2006). Some stylized facts about high speed rail around the world: an empirical approach [Electronic version]. *Transport policy*, 16, 1, 19-28.
- Centrum Vernieuwing Openbaar Vervoer (2005). *Kostenkengetallen Openbaar Vervoer* [Electronic version]. Rotterdam, The Netherlands: CVOV.
- Couto, A. & Graham, D.J. (2008). The impact of high-speed technology on railway demand [Electronic version]. *Transportation*, 35, 111-128.
- DB Netz AG (2009). *Infrastruktur gestalten*. Frankfurt am Main: Gerhard Brückmann.
- Dietmar, L., & Hecht, M. (2008). *Das System Bahn*. Hamburg, Germany: Eurailpress.
- European Commission (1996) *Guideline 96/48/EC of July 23 1996*. Retrieved June 6, 2010, from European Commission, Transport and Mobility website: http://ec.europa.eu/transport/infrastructure/networks_eu/rails_en.htm
- Fiedler, J. (1999). *Bahnwesen*. Düsseldorf, Germany: Werner.
- Heinisch, R. (2005). Systemkompetenz für Europas schnelle Bahnen. *Bahntech*, 3, 3.
- Latten, R. (2001). *Jahrbuch Europäische Eisenbahnen 2001*. Alkmaar, Niederlande: de Alk.
- Li, J. & Wachs, M. (2000). A test of intermodal performance measures for transit investment decisions. *Transportation* 27, 243-267.
- Mnich, P. (2006). *Stellenwert der Reisezeit in spurgeführten Personenfernverkehr*. Received June 24, 2010, from Technische Universität Berlin, Institut für Bahntechnik GmbH.
- Ortúzar, J. de Dios & Willemsen, L.G. (2006). *Modelling transport*. Chichester, Engeland: John Wiley & Sons.
- Pachl, J. (2010). *ETCS, Chancen oder Kostengrab für Deutschland und Europa*. Received July 6, 2010, from Technische Universität Berlin, Fachgruppe Schienenfahrwege und Bahnbetrieb.
- Panten, C. & Gralla, C. (2007). Einheitliches sicherheitssystem für die europäischen Eisenbahnen. *Güterbahnen*, 3, 18-22.
- Prorail (2010). *Netverklaring 2010, Gemengde net*. Retrieved June 4, 2010, from Prorail website: <http://www.prorail.nl/Vervoerders/Documents/20686705%20NV2010%20tm%20aanv7%201apr2010.pdf>.
- Signalsysteme* (n.d.). Retrieved June 24, 2010, from <http://www.stellwerke.de/signal/index.html>.
- Spoorwegbeveiliging* (n.d.). Retrieved June 8, 2010, from http://www.spoortechniek.nl/joomla/index.php?option=com_content&view=category&id=26&Itemid=47.
- Vickerman, R. (1997). High-speed rail in Europe: experience and issues for future development [Electronic version]. *The annals of Regional Science*, 3, 21-38.
- Zugsicherung* (n.d.). Retrieved June 8, 2010, from <http://www.marco-wegener.de/technik/index.htm>.

Appendix

Appendix A: Timetable IC Berlin Schiphol

Fahrplan IC Berlin - Hannover - Amsterdam - Schiphol

gültig bis 11. Dezember 2010

	IC 242	IC 240	IC 148 ²	IC 248 ³	IC 146	IC 144	IC 142	IC 140	
Berlin Ostbahnhof	ab	--	06:26 ¹	--	08:26	10:26	12:26	14:26	16:26
Berlin Hbf	ab	--	06:37 ¹	08:39	08:37	10:37	12:36	14:37	16:37
Berlin-Spandau	ab	--	06:54 ¹	08:54	08:54	10:54	12:54	14:54	16:54
Rathenow	ab	--	--	--	--	--	--	--	--
Stendal	ab	--	07:35 ¹	09:35	09:35	11:35	13:35	15:35	17:35
Wolfsburg	ab	--	08:05 ¹	10:05	10:05	12:05	14:05	16:05	18:05
Hannover Hbf	ab	06:40 ¹	08:40 ¹	10:40	10:40	12:40	14:40	16:40	18:40
Minden(Westf)	ab	07:12 ¹	09:12 ¹	11:12	11:12	13:12	15:12	17:12	19:12
Bad Oeynhausen	ab	07:22 ¹	--	11:22	11:22	--	15:22	--	19:22
Bünde(Westf)	ab	--	09:32 ¹	--	--	13:32	--	17:32	--
Osnabrück Hbf	ab	07:53 ¹	09:53 ¹	11:53	11:53	13:53	15:53	17:53	19:53
Rheine	ab	08:21 ¹	10:21 ¹	12:21	12:21	14:21	16:21	18:21	20:21
Bad Bentheim	ab	08:44	10:44	12:44	12:44	14:44	16:44	18:44	20:44
Hengelo	an	09:04	11:04	13:04	13:04	15:04	17:04	19:04	21:04
Almelo	an	09:17	11:17	13:17	13:17	15:17	17:17	19:17	21:17
Deventer	an	09:41	11:41	13:41	13:41	15:41	17:41	19:41	21:41
Apeldoorn	an	09:56	11:56	13:56	13:56	15:56	17:56	19:56	21:56
Amersfoort	an	10:22	12:22	14:22	14:22	16:22	18:22	20:22	22:22
Hilversum	an	10:36	12:36	14:36	14:36	16:36	18:36	20:36	22:38 ⁴
Duivendrecht	an	10:55	12:55	14:55	14:55	16:55	18:55	20:55	22:55
Amsterdam Zuid/WTC	an	11:02	13:02	15:02	15:02	17:02	19:02	21:02	23:02
Schiphol (Flughafen)	an	11:09	13:09	15:09	15:09	17:09	19:09	21:09	23:09
		täglich	täglich	Mo-Sa	So	täglich	täglich	täglich	täglich

¹ nur von Montag bis Samstag, verkehrt nicht am 24. Mai

² Zug beginnt in Stettin/Polen und verkehrt nicht am 24. Mai

³ verkehrt auch am 24. Mai

⁴ samstags und sonntags Ankunft um 22:36 Uhr, auch am 24. Mai

	IC 141	IC 143	IC 145 ¹	IC 245 ²	IC 147	IC 149	IC 241	IC 243	
Schiphol (Flughafen)	ab	06:49	08:49	10:49	10:49	12:49	14:49	16:49	18:49
Amsterdam Zuid/WTC	ab	06:58	08:58	10:58	10:58	12:58	14:58	16:58	18:58
Duivendrecht	ab	07:04	09:04	11:04	11:04	13:04	15:04	17:04	19:04
Hilversum	ab	07:21	09:21	11:21	11:21	13:21	15:21	17:21	19:21
Amersfoort	ab	07:37	09:37	11:37	11:37	13:37	15:37	17:37	19:37
Apeldoorn	ab	08:06	10:06	12:06	12:06	14:06	16:06	18:06	20:06
Deventer	ab	08:19	10:19	12:19	12:19	14:19	16:19	18:19	20:19
Almelo	ab	08:43	10:43	12:43	12:43	14:43	16:43	18:43	20:43
Hengelo	ab	08:58	10:58	12:58	12:58	14:58	16:58	18:58	20:58
Bad Bentheim	an	09:18	11:18	13:18	13:18	15:18	17:18	19:18	21:18
Rheine	an	09:40	11:40	13:40	13:40	15:40	17:40	19:40 ³	--
Osnabrück Hbf	an	10:06	12:06	14:06	14:06	16:06	18:06	20:06 ³	--
Bünde(Westf)	an	--	12:27	--	--	16:27	--	20:27 ³	--
Bad Oeynhausen	an	10:37	--	14:37	14:37	--	18:37	--	--
Minden(Westf)	an	10:47	12:47	14:47	14:47	16:47	18:47	20:47 ³	--
Hannover Hbf	an	11:18	13:18	15:18	15:18	17:18	19:18	21:18 ³	--
Wolfsburg	an	11:53	13:53	15:53	15:53	17:53	19:53	21:53 ⁴	--
Stendal	an	12:24	14:24	16:24	16:24	18:24	20:24	22:24 ⁴	--
Berlin-Spandau	an	13:03	15:03	17:01	17:01	19:03	21:03	23:03 ⁴	--
Berlin Hbf	an	13:20	15:20	17:12	17:20	19:20	21:20	23:20 ⁴	--
Berlin Ostbahnhof	an	13:31	15:31	--	17:30	19:31	21:30	23:30 ⁴	--
		täglich	täglich	Mo-Fr, So	Sa	täglich	täglich	täglich	täglich

¹ Zug endet in Stettin/Polen und verkehrt nicht am 23. Mai

² verkehrt auch am 23. Mai

³ nicht an Samstagen und nicht am 23. Mai

⁴ IC 241 fährt freitags und sonntags bis nach Berlin Ostbahnhof

Stand: 03. Mai 2010

Appendix B: Elaboration on train control systems

German train control systems

The in Germany applied train control systems can be separated into two types, as is depicted in Table 5. These types are the point formed system and the line formed system. Of each of these systems several versions or variants exist that were developed throughout the years.

The point formed train control system (Punktförmige Zugbeeinflussung, PZB), before called inductive train safeguarding (Indusi), is designed to trigger a compulsory emergency brake when a train driver passes a stop displaying main signal, a warning displaying prior signal, a railway crossing safety signal or disregards the speed limitations. This system establishes a point formed monitoring process between the track based signals and a train. Because monitoring only takes place at certain points in the track this safety system is called point formed. Though PZB does not replace the train driver and most certainly does not relieve his accountability it is merely an attachment (Zugsicherung, n.d.).

The functions that PZB guards are:

- Testing the train driver's watchfulness at a stop announcing signal by requesting to push a button to validate the displayed signal.
- Monitoring the trains braking path before a stop displaying signal. With older systems this is done by discrete monitoring and more commonly with continuous braking path monitoring.
- Performing a compulsory emergency braking when passing a stop displaying signal.

On the right side of the track a magnet is mounted consisting of a coil linked parallel with a capacitor, which is set to a frequency of 500Hz, 1000Hz or 2000Hz. These magnets can be switched on or off depending on the signal display and so be active or non- active. On the train an electromagnet is mounted that induces all three frequencies. When the train passes an active track magnet the electromagnetic field of the train magnet induces an electrical current in the track magnet. The active track magnet drains power from the train magnet which is registered by the train and converted to a monitoring action (Zugsicherung, n.d.).

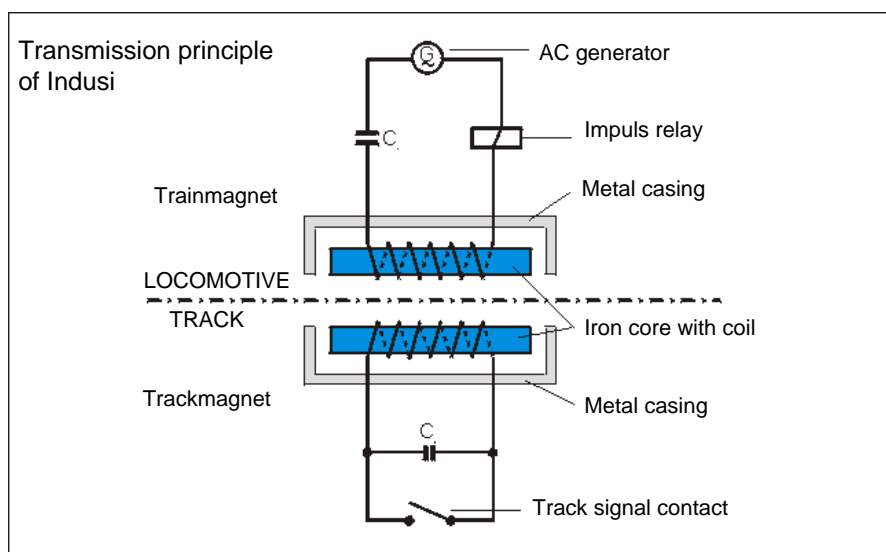

Figure 13: Graphic display of the PZB transmission principle (Zugsicherung, n.d.)

PZB 90 is an improvement of the outdated PZB system with the main goal to unite East- and West-German safety systems after the fall of the wall. The main improvements were made on the speed monitoring functions to increase operating safety. Also the safeguarding needed to be completed when accidentally passing a stop displaying signal at low speeds or passing a stop displaying signal after correctly observing the prior signal.

Track sections with the DB that can be operated with a maximum speed higher than 160km/h need to be equipped with the line formed train influencing system (Linien Zugbeeinflussung, LZB). This system can also be used to increase section capacity on normal track. This is because with LZB the section of track needed for ensuring a safety block section between two trains can be reduced and can theoretically even drive at braking path distance from one another (Zugsicherung, n.d.).

LZB is a computer based train control system that secures a train by continuously monitoring the train speed and guides it by showing instructions on the driver's display or by automatic speed control. With LZB the driver can drive on electronic display signalling that can reach over several track sections and shows the availability of the track sections and the train braking path (Zugsicherung, n.d.).

Because trains with LZB are not bound to track based signals and the corresponding braking path of 1000m they can drive with a higher speed. The reduction of the safety block section size due to LZB allows train density to be raised. With LZB is secured that trains don't surpass the speed limit, don't leave the released track sections and that signals are shown on the driver's display.

With LZB a loop of electric cable is placed between the tracks that functions as antenna. One side of the loop is in the middle the other on the foot of the rails. Every 100m the cable is crossed, which causes the current to change. This system is graphically displayed in Figure 14. These points of crossing are distance referencing points for the train. In between these points the train determines its location on the track by counting wheel rotations. This means that the train can determine its location with pin point accuracy, which is of great importance when it comes to monitoring the trains braking path.

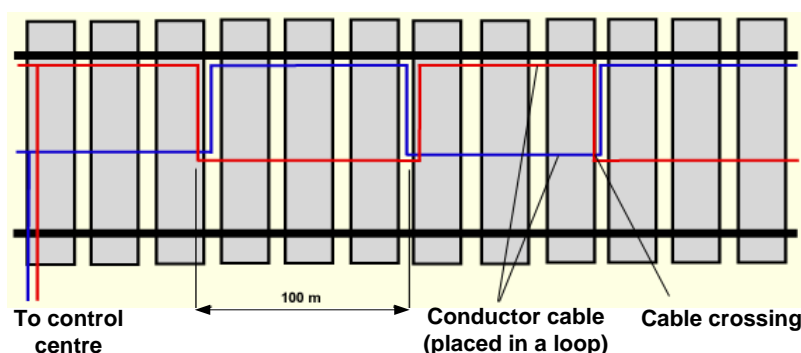

Figure 14: Graphic display of LZB (Source; ETR 11/2000)

Thanks to this continuous data transfer safety blocks are no longer location bound but can move along with the train in a so called moving block. This makes it possible to let trains follow one another closer and so increases the track capacity. This gain in capacity is maximized when following trains have the same speed. When trains with different speeds and braking paths use the same track, as is the case in Germany, the gain in capacity is minimal.

Dutch train control system

The Dutch train control system ATB has the same functions as the German system. Though the techniques used to transfer the signal is completely different. The ATB system uses the conductivity of the rails itself. An alternating current is placed on the rails, the one rails negative and the other positive. Normally the circuit is closed using a relay, but when a train passes the axes of the train close the circuit which can be detected. However the current that flows through these rails is not continuously. The emitted alternating current is interrupted with certain different frequencies that are the source of the ATB code (Spoorwegbeveiliging, n.d.).

The current that flows through the axes of the train causes a magnetic field to form around the wheels. This magnetic field is measured with coils mounted on the train and so the interruption frequency and thus the ATB code is transferred. For every indicated speed a different code exists though there are a limited number of codes available. The registered code is displayed in the cabin as the maximum allowed speed. A major disadvantage here is that not all speeds can be shown in the on the display. For example there is a code available for both 80km/h and 130km/h, but when a track based signal shows 100km/h the ATB will show 130km/h. This can cause dangerous situations relying on the driver to decide whether or not to oblige the track based signal (Spoorwegbeveiliging, n.d.).

Another problem that arises with ATB happens at low velocity (under 40km/h) where the ATB not always triggers a response when a driver passes a red signal. This problem is solved with new versions of the ATB system and is applied on almost all stations. Several other versions of ATB exist, such as the ATB+ version that allows for speeds up to 160km/h instead of 140km/h. Another is ATB second generation which uses track based beacons, which means that a train without ATBng cannot operate on a track which is equipped for ATBng and vice versa (Latten, 2001). This causes a reduction in national interoperability. All these systems are relatively new while ATB was only introduced in the 1950's and the application of ATB on the entire network was only completed in the 1990's.

European Train Control System (ETCS)

ETCS consist of three levels of control. Level 1 consists of an interoperable point formed train control system in which Information is transferred through a switchable Eurobalise and when applied with short conductive cable loops (Euroloop). Within this level two sub- levels can be distinguished; limited supervision and full supervision. The difference lies in the application of Euroloop and Euradio with full supervision which allows a more continuous data transfer to the train, which makes it possible to drive past signals with higher speeds (Zugsicherung, n.d.).

Level 2 is a line formed train control system in which data transfer is based on a mobile radio signal complying with the GSM-R standard. Pin pointing train locations is achieved with a non switchable Eurobalise that functions as electronic kilometre signs. Track based signals are no longer necessary while all the information is electronically transferred to the driver's display (Eurocab). This level of ETCS can be compared with the German LZB train control system. The command centre supplies the train with the necessary data such as track availability, maximum allowed speed and the prospective speeds as static data. On board the train the dynamic speed profile is then calculated depending on the braking parameters of the train. The track free notification can be given by track based apparatus that counts the axes of the train and this way monitors if it has completely passed (Zugsicherung, n.d.).

Level 3 is a radio based, with the GSM-R standard (Euradio), train control system. Determining the position off the train is done the same as with level 2, that is with non switchable Eurobalises. On this level the train's integrity is guarded on board the train itself. Thanks to the continuous positioning signal that is sent to the command centre and the automatic integrity check it is now possible to say with certainty which section the train has already cleared. When the intervals of sending positioning information are sufficient, almost continuous, it is possible to drive within absolute braking distance, also known as driving with a moving block (Zugsicherung, n.d.).